

INSTALLATION, OPERATING AND SERVICE INSTRUCTIONS

EVCA SERIES CONDENSING BOILER

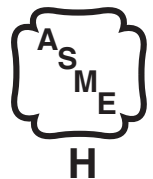

File Number MH25585

For service and repairs to the heating plant, call your heating contractor. When seeking information on the boiler from the manufacturer, provide boiler model and serial number as shown on rating label.

Boiler Model EVCA -	Installation Date	Serial Number	Type System
Heating Contractor			
Address		Phone Number	

Your Local Thermal Solutions Representative:

814EVC003 R6-08/16



IMPORTANT INFORMATION - READ CAREFULLY

NOTE: Post these instructions and maintain in legible condition.

NOTE: The equipment shall be installed in accordance with those installation regulations required in the area where the installation is to be made. These regulations shall be carefully followed in all cases. Authorities having jurisdiction shall be consulted before installations are made.

All wiring on boilers installed in the USA shall be in accordance with the National Electrical Code and/or local regulations.

All wiring on boilers installed in Canada shall be in accordance with the Canadian Electrical Code and/or local regulations.

The following terms are used throughout this manual to bring attention to the presence of hazards of various risk levels, or to important information concerning product life.

DANGER

Indicates an imminently hazardous situation which, if not avoided, will result in death, serious injury or substantial property damage.

CAUTION

Indicates a potentially hazardous situation which, if not avoided, may result in moderate or minor injury or property damage.

WARNING

Indicates a potentially hazardous situation which, if not avoided, could result in death, serious injury or substantial property damage.

NOTICE

Indicates special instructions on installation, operation, or maintenance which are important but not related to personal injury hazards.

DANGER

DO NOT store or use gasoline or other flammable vapors or liquids in the vicinity of this or any other appliance.

If you smell gas vapors, **DO NOT** try to operate any appliance - **DO NOT** touch any electrical switch or use any phone in the building. Immediately, call the gas supplier from a remotely located phone. Follow the gas supplier's instructions or if the supplier is unavailable, contact the fire department.

WARNING

This boiler requires regular maintenance and service to operate safely. Follow the instructions contained in this manual.

Improper installation, adjustment, alteration, service, or maintenance can cause property damage, personal injury or loss of life. Read and understand the entire manual before attempting installation, start-up, operation, or service. Installation and service must be performed only by an experienced, skilled installer or service agency.

This boiler must be properly vented.

This boiler needs fresh air for safe operation and must be installed so there are provisions for adequate combustion and ventilation air.

The interior of the venting and air intake systems must be inspected and cleaned before the start of the heating season and should be inspected periodically throughout the heating season for any obstructions. Clean and unobstructed venting and air intake systems are necessary to allow noxious fumes that could cause injury or loss of life to vent safely and will contribute toward maintaining the boiler's efficiency.

This boiler is supplied with safety devices which may cause the boiler to shut down and not re-start without service - If damage due to frozen pipes is a possibility, the heating system should not be left unattended in cold weather; or appropriate safeguards and alarms should be installed on the heating system to prevent damage if the boiler is inoperative.

This boiler contains very hot water under high pressure. Do not unscrew any pipe fittings nor attempt to disconnect any components of this boiler without positively assuring the water is cool and has no pressure. Always wear protective clothing and equipment when installing, starting up or servicing this boiler to prevent scald injuries. Do not rely on the pressure and temperature gauges to determine the temperature and pressure of the boiler. This boiler contains components which become very hot when the boiler is operating. Do not touch any components unless they are cool.

Boiler materials of construction, products of combustion and the fuel contain alumina, silica, heavy metals, carbon monoxide, nitrogen oxides, aldehydes and/or other toxic or harmful substances which can cause death or serious injury and which are known to the state of California to cause cancer, birth defects and other reproductive harm. Always use proper safety clothing, respirators and equipment when servicing or working nearby the appliance.

Failure to follow all instructions in the proper order can cause personal injury or death. Read all instructions, including all those contained in component manufacturers manuals which are provided with the boiler before installing, starting up, operating, maintaining or servicing.

Keep boiler area clear and free from combustible materials, gasoline and other flammable vapors or liquids.

All cover plates, enclosures and guards must be in place at all times.

This product must be installed by a licensed plumber or gas fitter when installed within the Commonwealth of Massachusetts.

NOTICE

This boiler has a limited warranty, a copy of which is printed on the back of this manual. It is the responsibility of the installing contractor to see that all controls are correctly installed and are operating properly when the installation is complete.

Table of Contents

I. Pre-Installation..... 8	A. Safety and Operating Controls..... 49
II. Unpacking the Boiler 9	B. Troubleshooting 50
III. Installation 10	C. Periodic Maintenance..... 52
A. Venting 10	D. Inspection & Cleaning Procedure ... 53
B. Combustion Air 15	VIII. Repair Parts 57
C. Water Treatment 17	IX. Thermal Solutions Boiler Control™
D. Water Piping and Trim..... 18	(TSBC™) 85
E. Gas Piping..... 21	A. Introduction 85
F. Electrical 24	B. Front Panel Display 86
G. Modular Systems..... 31	C. Security Menu 88
H. Condensate Drains 40	D. Setup Menu..... 89
IV. System Start-up 41	E. Boiler Configuration Menu..... 92
V. Lighting Instructions..... 44	F. System Configuration Menu 93
VI. Boiler Operational Sequence..... 46	G. Setpoints Menu 94
VII. Service/Maintenance..... 48	H. Communication Menu 95
	I. Manual Mode Menu 96
	X. Warranty Back Cover

Minimum Clearance to Combustible Materials

<u>Left Side</u>	<u>Right Side</u>	<u>Front</u>	<u>Rear</u>	<u>Top</u>	<u>Flue Connector</u>
6"	6"	24"	6"	6"	18"

Recommended Clearance for Service

<u>Boiler Size</u>	<u>Left Side</u>	or	<u>Right Side</u>	<u>Front and</u>	<u>Rear</u>	<u>Top</u>
750/1000	24"		24"	24"	24"	16"
1500	24"		24"	24"	24"	19"
2000	24"		24"	24"	24"	31"
3000	24"		24"	36"	36"	26.5"

NOTES:

- 1. When 3 or more units are mounted side-by-side, the front service clearance increases by 12" and the rear service clearance increases by 24".**
- 2. Verify clearances with local codes.**
- 3. Net AHRI Ratings**
 - A. The Net AHRI Water Ratings shown are based on a piping and pickup allowance of 1.15.
 - B. The manufacturer should be consulted before selecting a boiler for installations having unusual piping and pickup requirements, such as intermittent system operation, extensive piping systems, etc.
 - C. The ratings have been determined under the provisions governing forced draft boiler-burner units.

Notes:

1. Piping removed for visual clarity.
2. See notes concerning Net AHRI Ratings on page 4.

EVCA-750

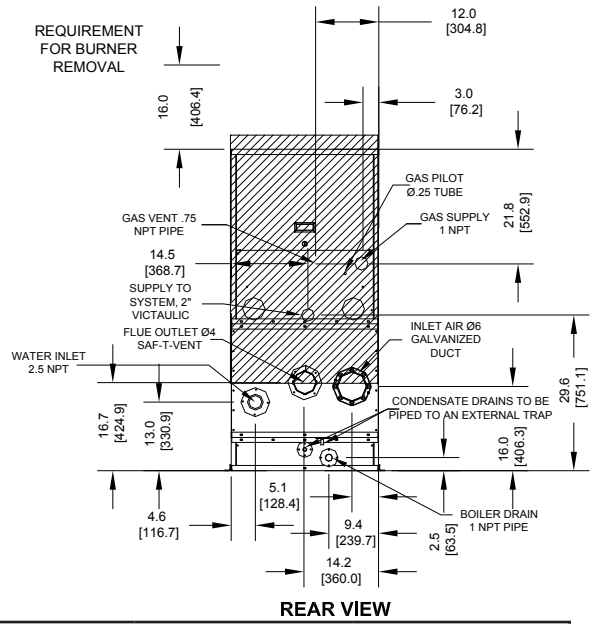
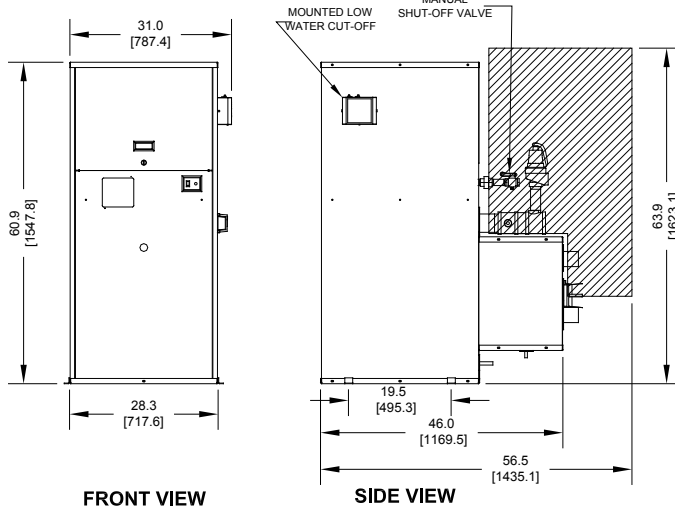

BOILER MODEL NUMBER				CAPACITIES		
	INPUT (MBH)	GROSS OUTPUT (MBH)	NET AHRI RATING (MBH) ²	WATER VOLUME (gallons)	DRY WEIGHT (lbs.)	WET WEIGHT (lbs.)
EVCA-750	750	699	608	16.7	1,401	1,672
EVCA-1000	1,000	939	817	18.4	1,518	1,868

BOILER MODEL RANGE	ELECTRICAL			
	SUPPLY (volts/Hz/phase)	blower motor (hp)	pump motor (hp)	Nominal power draw (amps)
750/1000	120/60/1	1 1/2	1/4	12.8
	208/60/1			9.1
	230/60/1			9.0
	208/60/3			7.4
	230/60/3			7.3
	460/60/3			6.3

EVCA-1000

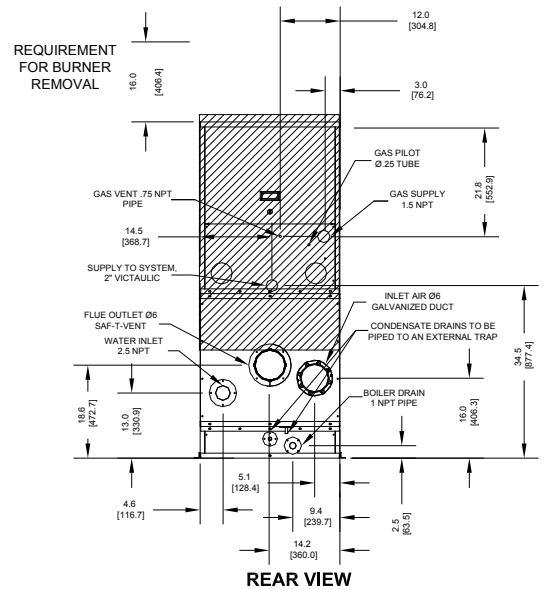
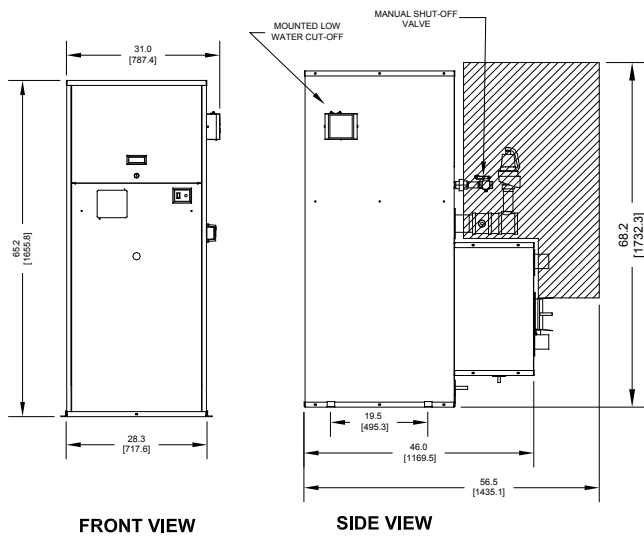
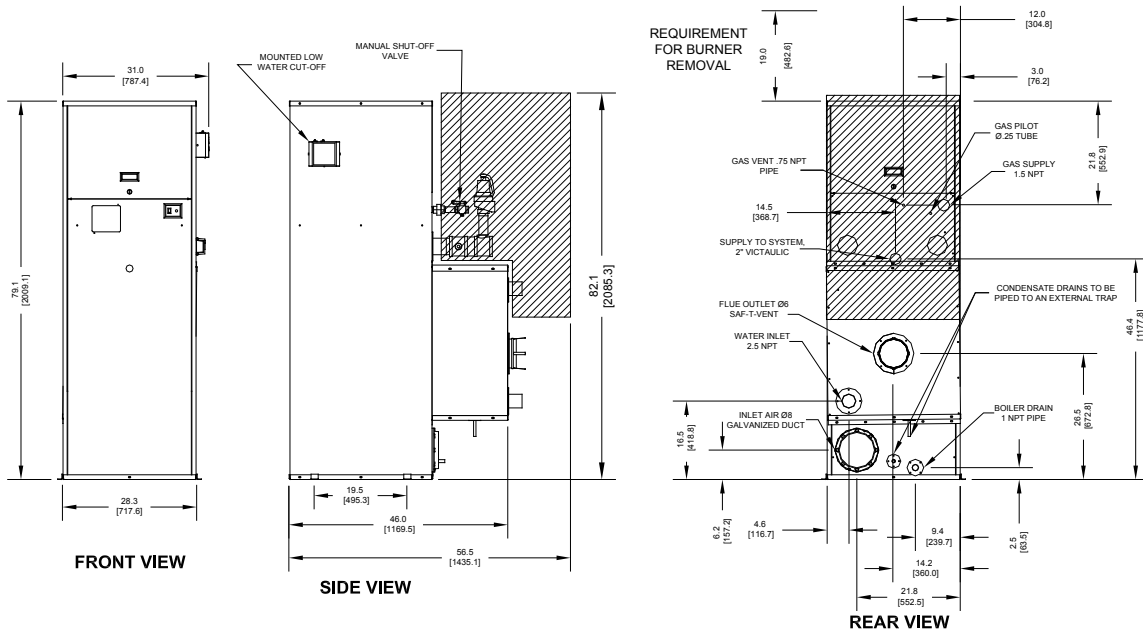

Figure 1a: Dimensions and Capacities EVCA 750 & 1000

EVCA-1500

Notes:

1. Piping removed for visual clarity.
2. See notes concerning Net AHRI Ratings on page 4.



BOILER MODEL NUMBER	AHRI CERTIFIED® www.ahridirectory.org			CAPACITIES		
	INPUT (MBH)	GROSS OUTPUT (MBH)	NET AHRI RATING (MBH) ²	WATER VOLUME (gallons)	DRY WEIGHT (lbs.)	WET WEIGHT (lbs.)
EVCA-1500	1,500	1,420	1,235	19.8	1,704	1,994
EVCA-2000	2,000	1,900	1,652	21.2	1,897	2,163

BOILER MODEL RANGE	ELECTRICAL			
	SUPPLY (volts/Hz/phase)	blower motor (hp)	pump motor (hp)	Nominal power draw (amps)
1500/2000	120/60/1	1 1/2	3/4	19.3
	208/60/1			11.9
	230/60/1			11.8
	208/60/3			9.3
	230/60/3			9.0
	460/60/3			4.5

EVCA-2000

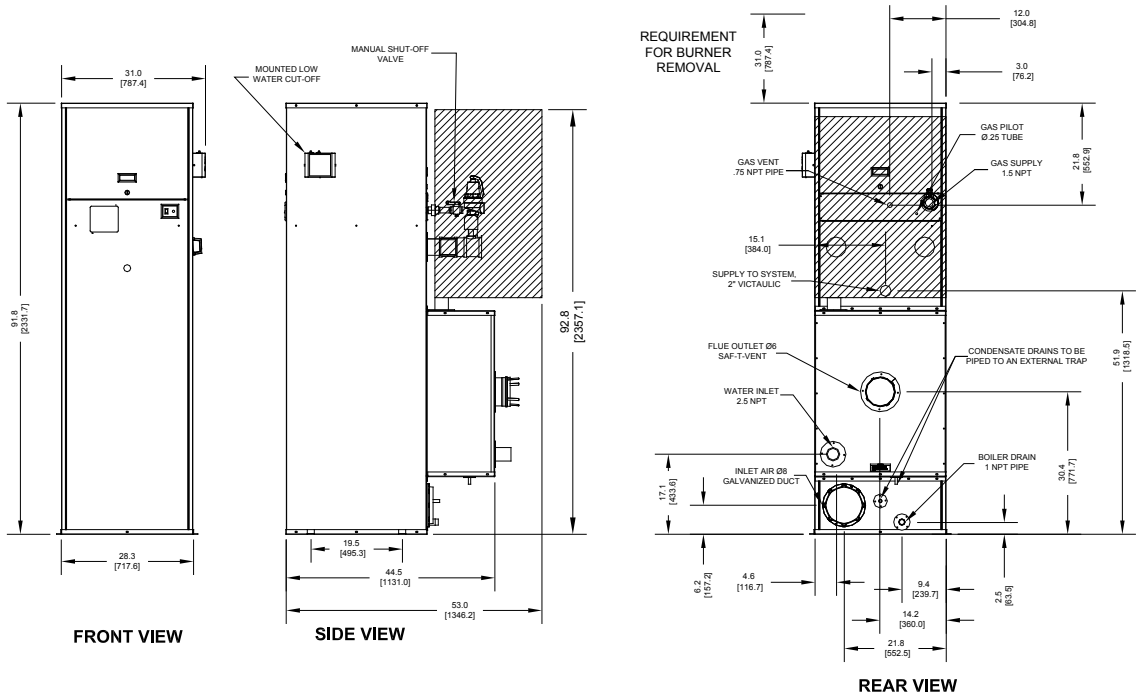
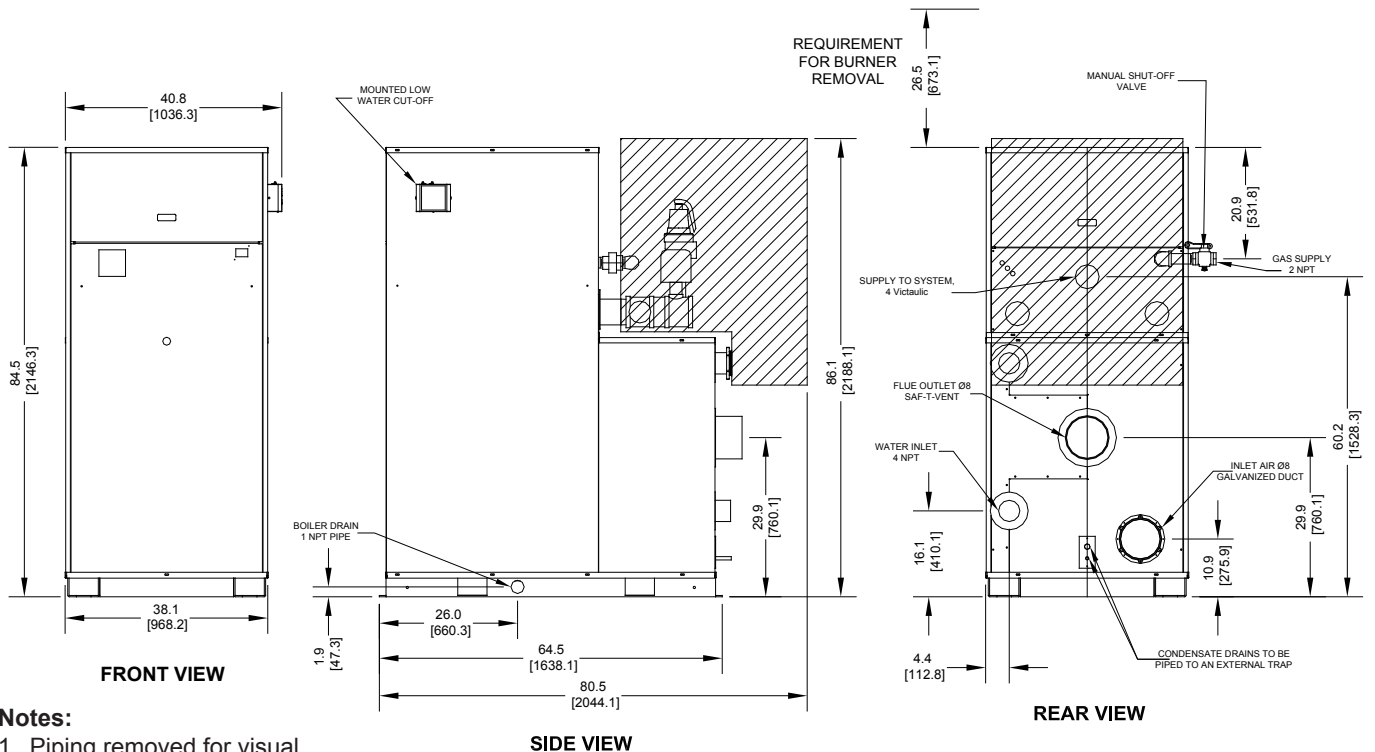



Figure 1b: Dimensions and Capacities EVCA 1500 & 2000



- Notes:**
1. Piping removed for visual clarity.
 2. See notes concerning Net AHRI Ratings on page 4.

BOILER MODEL NUMBER				CAPACITIES			
	INPUT (MBH)	GROSS OUTPUT (MBH)	NET AHRI RATING (MBH) ²	WATER VOLUME (gallons)	HEAT TRANSFER AREA (sq.ft.)	DRY WEIGHT (lbs.)	WET WEIGHT (lbs.)
EVCA-3000	3,000	2,910	2,530	53.9	1,426	3,354	3,803

BOILER MODEL	ELECTRICAL			
	SUPPLY (volts/Hz/phase)	blower motor (hp)	pump motor (hp)	Nominal power draw (amps)
EVCA-3000	208/60/3	2	2	14.6
	230/60/3			13.9
	460/60/3			7.0

Figure 1c: Dimensions and Capacities EVCA 3000

I. Pre-Installation

WARNING

Carefully read all instructions before installing boiler. Failure to follow all instructions in proper order can cause personal injury or death.

- A. Installation must conform to the requirements of the authority having jurisdiction. In the absence of such requirements, installation must conform to the *National Fuel Gas Code*, NFPA 54/ANSI Z223.1, and/or CAN/CGA B149 Installation Codes. Where required by the authority having jurisdiction, the installation must conform to the *Standard for Controls and Safety Devices for Automatically Fired Boilers*, ANSI/ASME CSD-1.
- B. The boiler is not design certified for installation on combustible flooring. The boiler must not be installed on carpeting.
- C. Provide clearance between boiler jacket and combustible material in accordance with local fire ordinance. Refer to page 4 of this manual for minimum listed clearance from combustible material.
- D. Install on level floor. For basement installation provide concrete base if floor is not perfectly level or if water may be encountered on floor around boiler. Floor must be able to support weight of boiler, water and all additional system components.
- E. Protect gas ignition system components from water (dripping, spraying, rain, etc.) during boiler operation and service (circulator replacement, condensate trap service, control replacement, etc.).
- F. Provide combustion and ventilation air in accordance with applicable provisions of local building codes or: USA - *National Fuel Gas Code*, NFPA 54/ANSI Z223.1, Section 5.3, Air for Combustion and Ventilation; Canada - *Natural Gas Installation Code*, CAN/CGA - B149.1, or *Propane Installation Code*, CAN/CGA - B.149.2, Part 5, Venting Systems and Air Supply for Appliances.

WARNING

Adequate combustion and ventilation air must be provided to assure proper combustion.

The following guideline is based on the *National Fuel Gas Code*, NFPA 54/ANSI Z223.1.

1. Determine volume of space (boiler room). Rooms communicating directly with space (through openings not furnished with doors) are considered part of space.
Volume [ft³] = Length [ft] x Width [ft] x Height [ft]
2. Determine Total Input of all appliances in space. Round result to nearest 1,000 Btu per hour (Btuh).
3. Determine type of space. Divide Volume by Total Input.
 - a. If result is greater than or equal to 50 ft³ per 1,000 Btuh, space is considered an *unconfined space*.
 - b. If result is less than 50 ft³ per 1,000 Btuh, space is considered a *confined space*.
4. Determine building type. A building of *unusually tight construction* has the following characteristics:
 - a. Walls and ceiling exposed to outside atmosphere have a continuous water vapor retarder with a rating of 1 perm or less with openings gasketed and sealed, and;
 - b. Weather-stripping has been added on openable windows and doors, and;
 - c. Caulking or sealants applied in joints around window and door frames, between sole plates and floors, between wall-ceiling joints, between wall panels, at plumbing and electrical penetrations, and at other openings.
5. For boiler located in an *unconfined space in a building of other than unusually tight construction*, adequate combustion and ventilation air is normally provided by fresh air infiltration through cracks around windows and doors.

NOTICE

Boilers operated with sealed combustion are exempt from needing provisions for combustion air from the room, provided air intake piping is installed per code and the instructions in this manual.

6. For boiler located within *unconfined space in building of unusually tight construction* or within *confined space*, provide outdoor air through two permanent openings which communicate directly or by duct with the outdoors or spaces (crawl or attic) freely communicating with the outdoors. Locate one opening within 12 inches of top of space. Locate remaining opening within 12 inches of bottom of space. Minimum dimension of air opening is 3 inches. Size each opening per the following:

- a. Direct communication with outdoors. Minimum free area of 1 square inch per 4,000 Btu per hour input of all equipment in space.
- b. Vertical ducts. Minimum free area of 1 square inch per 4,000 Btu per hour input of all equipment in space. Duct cross-sectional area shall be same as opening free area.
- c. Horizontal ducts. Minimum free area of 1 square inch per 2,000 Btu per hour input of all equipment in space. Duct cross-sectional area shall be same as opening free area.

Alternate method for boiler located within confined space. Use indoor air if two permanent openings communicate directly with additional space(s) of sufficient volume such that combined volume of all spaces meet criteria for unconfined space. Size each opening for minimum free area of 1 square inch per 1,000 Btu per hour input of all equipment in spaces, but not less than 100 square inches.

- 7. Ventilation Duct Louvers and Grilles. Equip outside openings with louvers to prevent entrance of rain and snow, and screens to prevent entrance of insects and rodents. Louvers and grilles must be fixed in open position or interlocked with equipment to open automatically before burner operation. Screens must not be smaller than ¼ inch mesh.

Consider the blocking effect of louvers, grilles and screens when calculating the opening size to provide the required free area. If free area of louver or grille is not known, assume wood louvers have 20-25 percent free area and metal louvers and grilles have 60-75 percent free area.

DANGER

Do not install boiler where gasoline or other flammable vapors or liquids, or sources of hydrocarbons (i.e. bleaches, cleaners, chemicals, sprays, paint removers, fabric softeners, etc.) are used or stored.

NOTICE

Due to the low water content of the boiler, incorrect sizing of the boiler with regard to the heating system load will result in excessive boiler cycling and accelerated component failure. Thermal Solutions DOES NOT warrant failures caused by incorrectly sized boiler applications. DO NOT oversize the boiler to the system. Modular boilers greatly reduce the likelihood of boiler oversizing.

II. Unpacking the Boiler

NOTICE

Boiler crate is equipped with a tip & tell label. If label indicates boiler has been tipped over during shipping, remove crate and inspect before trucker leaves.

CAUTION

Do not drop boiler. Do not bump boiler jacket against floor.

- A. Move boiler to approximate installed position.
- B. Remove all crate fasteners.
- C. Open outside container and remove all inside protective spacers and bracing.
- D. Remove all boiler hold-down fasteners.

WARNING

Installation of this boiler should be undertaken only by trained and skilled personnel from a qualified service agency.

- E. Remove unit from shipping skid (if provided.)
 - 1. Tilt the boiler to one side and slide a small roller under the raised base.
 - 2. Tilt the boiler to the other side and slide another roller under the base.
 - 3. Place a larger pipe roller on floor behind the skid.
 - 4. Roll the boiler forward or backward off the skid and onto the pipe roller.
- F. Move boiler to its permanent location.

WARNING

Boiler air vent is shipped loose for EVCA 750-2000. Refer to water piping and trim section prior to filling the boiler with water.

III. Installation

A. VENTING

WARNING

Improper venting may result in property damage and the release of flue gasses which contain deadly carbon monoxide (CO) into the building, which can cause severe personal injury and/or death.

1. Venting Requirements

In order to properly vent this boiler, the installer must select and install a vent system that meets all requirements specified in this section (VENTING) as well as following the instructions provided by the vent system manufacturer.

- a. The vent system shall be designed and constructed in accordance with the National Fuel Gas Code/NFPA 54 ANSI Z223.1 and applicable local building codes to develop a positive flow adequate to convey flue or vent gasses to the outdoors.
- b. If this boiler is being installed in Massachusetts, follow the Massachusetts Code instructions printed later in this section.
- c. Consult the vent pipe manufacturer's instructions for vent system assembly and system specific installation requirements.

WARNING

Vent pipe system must be made of materials approved for use with condensing flue gasses.

- d. Vent pipe system shall be acceptable for use with boiler fuel type.
- e. Vent pipe system shall be compatible either by directly connecting, or by use of an adapter, to the boiler vent connection.
 - i. This boiler is shipped with an AL 29-4C® Heat-Fab Saf-T-Vent connection.
 - ii. Alteration of the boiler vent connection is prohibited.
- f. Do not reduce the diameter of the vent pipe. The vent pipe must not be smaller than the vent connector on the boiler.

- g. Vent pipe system must be adequately supported at intervals no less than five (5) feet apart. The completed vent system must be rigid and able to withstand impacts without collapse.
- h. This boiler's venting is Category IV (positive vent pressure, flue condensing), with regards to National Fuel Gas Code/NFPA 54 ANSI Z223.1.
- i. Vent pipe system must be fully sealed.
- j. Atmospheric venting is prohibited.
- k. For multiple boiler installations, each boiler must have its own independent vent system. Common venting with additional or any other appliances is prohibited.

WARNING

Do not use vent dampers or barometric dampers with this boiler.

- l. **Direct vent applications:** For direct vent (ducted combustion air) installations, the maximum vent length is 50 equivalent feet. The vent length is equal to the total length of straight pipe plus the equivalent length of vent fittings.
- m. **Non-direct vent applications:** For non-direct vent installations (those without ducted combustion air), design the vent system so that the pressure measured at the outlet of the boiler is between 0" w.c. and 0.3" w.c. at high fire.
- n. If any point of the vent pipe system is higher than the boiler flue collar, the vent system must have adequate condensate drain loop(s) to prevent condensate from running back into the boiler.
- o. It is permissible to run vent pipe through a vertical or horizontal chase provided minimum clearances to combustible materials are maintained.
- p. The minimum clearance to combustible material is six (6) inches, unless otherwise specified by vent manufacturer.
- q. Horizontal vent pipe must slope no less than one (1) inch in four (4) feet of run. For sidewall venting, slope pipe toward vent termination if possible.
- r. The vent termination location is restricted as follows:
 - i. Minimum twelve (12) inches above grade plus normally expected snow accumulation or seven (7) feet above grade if located adjacent to public walkways. DO NOT INSTALL over public walkway where local experience indicates condensation or vapor from the boiler creates a nuisance or hazard.

- ii. Minimum three (3) feet above any forced air inlet located within ten (10) feet of the vent termination.
- iii. Minimum four (4) feet below, four (4) feet horizontally or one (1) foot above any door, window or gravity air inlet.
- iv. Minimum four (4) feet horizontally from electric meters, gas meters, regulators and relief valves. This distance may be reduced if equipment is protected from damage due to condensation or vapor by enclosure, overhangs, etc.
- v. Minimum twelve (12) inches from corners of building.
- s. Use appropriately designed thimbles when passing through combustible walls or roofs.
- t. Install fire-stops where vent passes through floors, ceilings or framed walls. The fire-stop must close the opening between the vent pipe and the structure.
- u. Enclose vent passing through occupied or unoccupied spaces above the boiler with materials having a fire resistance rating at least equal to the rating of the adjoining floor or ceiling. Maintain minimum clearance to combustible materials.
- v. Locate vent terminal above combustion air intake terminal (if used) and no closer than one (1) foot horizontally.
- w. Vertical venting requires flashing and a storm collar to prevent moisture from entering the structure.
- x. Vertical vent termination must be at least two (2) feet plus the expected snow accumulation above roof penetration height.

2. General Guidelines

- a. This boiler has been certified with AL29-4C® venting. Select a vent material that is approved for use with condensing flue gasses.
- b. Install vent system before installing air intake, water, gas or electrical connections.
- c. For instances where the vent system manufacturer's instructions do not make a specification, refer to the below points.
 - i. Make sure pipe and fittings are clean by swabbing with alcohol. Use Dow Corning 736 or 732 RTV, Polybar #500 RTV or Sil-bond 4500 or 6500 to seal vent pipe.
 - ii. Refer to the appropriate drawings in this section of this manual to determine common acceptable configurations of venting system.

3. IMPORTANT

The **Commonwealth of Massachusetts** requires compliance with regulation 248 CMR 4.00 and 5.00 for installation of side-wall vented gas appliances as follows:

- a. For all side wall horizontally vented gas fueled equipment installed in every dwelling, building or structure used in whole or in part for residential purposes, including those owned or operated by the Commonwealth and where the side wall exhaust vent termination is less than seven (7) feet above finished grade in the area of the venting, including but not limited to decks and porches, the following requirements shall be satisfied:
 1. **INSTALLATION OF CARBON MONOXIDE DETECTORS.** At the time of installation of the side wall horizontal vented gas fueled equipment, the installing plumber or gasfitter shall observe that a hard wired carbon monoxide detector with an alarm and battery back-up is installed on the floor level where the gas equipment is to be installed. In addition, the installing plumber or gasfitter shall observe that a battery operated or hard wired carbon monoxide detector with an alarm is installed on each additional level of the dwelling, building or structure served by the side wall horizontal vented gas fueled equipment. It shall be the responsibility of the property owner to secure the services of qualified licensed professionals for the installation of hard wired carbon monoxide detectors.
 - a. In the event that the side wall horizontally vented gas fueled equipment is installed in a crawl space or an attic, the hard wired carbon monoxide detector with alarm and battery back-up may be installed on the next adjacent floor level.
 - b. In the event that the requirements of this subdivision can not be met at the time of completion of installation, the owner shall have a period of thirty (30) days to comply with the above requirements; provided, however, that during said thirty (30) day period, a battery operated carbon monoxide detector with an alarm shall be installed.
 2. **APPROVED CARBON MONOXIDE DETECTORS.** Each carbon monoxide detector as required in accordance with the above provisions shall comply with NFPA 720 and be ANSI/UL 2034 listed and IAS certified.
 3. **SIGNAGE.** A metal or plastic identification plate shall be permanently mounted to the exterior of the building at a minimum height of eight (8) feet above grade directly in line with the exhaust vent terminal for the horizontally vented gas fueled heating appliance or equipment. The sign shall read, in print size no less than one-half (1/2) inch in size, "GAS VENT DIRECTLY BELOW. KEEP CLEAR OF ALL OBSTRUCTIONS".

4. INSPECTION. The state or local gas inspector of the side wall horizontally vented gas fueled equipment shall not approve the installation unless, upon inspection, the inspector observes carbon monoxide detectors and signage installed in accordance with the provisions of 248 CMR 5.08(2)(a)1 through 4.
- b. EXEMPTIONS: The following equipment is exempt from 248 CMR 5.08(2)(a)1 through 4:
 1. The equipment listed in Chapter 10 entitled "Equipment Not Required To Be Vented" in the most current edition of NFPA 54 as adopted by the Board; and
 2. Product Approved side wall horizontally vented gas fueled equipment installed in a room or structure separate from the dwelling, building or structure used in whole or in part for residential purposes.
- c. MANUFACTURER REQUIREMENTS - GAS EQUIPMENT VENTING SYSTEM PROVIDED. When the manufacturer of Product Approved side wall horizontally vented gas equipment provides a venting system design or venting system components with the equipment, the instructions provided by the manufacturer for installation of the equipment and the venting system shall include:
 1. Detailed instructions for the installation of the venting system design or the venting system components; and
 2. A complete parts list for the venting system design or venting system.
- d. MANUFACTURER REQUIREMENTS - GAS EQUIPMENT VENTING SYSTEM NOT PROVIDED. When the manufacturer of a Product Approved side wall horizontally vented gas fueled equipment does not provide the parts for venting the flue gases, but identifies "special venting systems", the following requirements shall be satisfied by the manufacturer:
 1. The referenced "special venting system" instructions shall be included with the appliance or equipment installation instructions; and
 2. The "special venting systems" shall be Product Approved by the Board, and the instructions for that system shall include a parts list and detailed installation instructions.
- e. A copy of all installation instructions for all Product Approved side wall horizontally vented gas fueled equipment, all venting instructions, all parts lists for venting instructions, and/or all venting design instructions shall remain with the appliance or equipment at the completion of the installation.

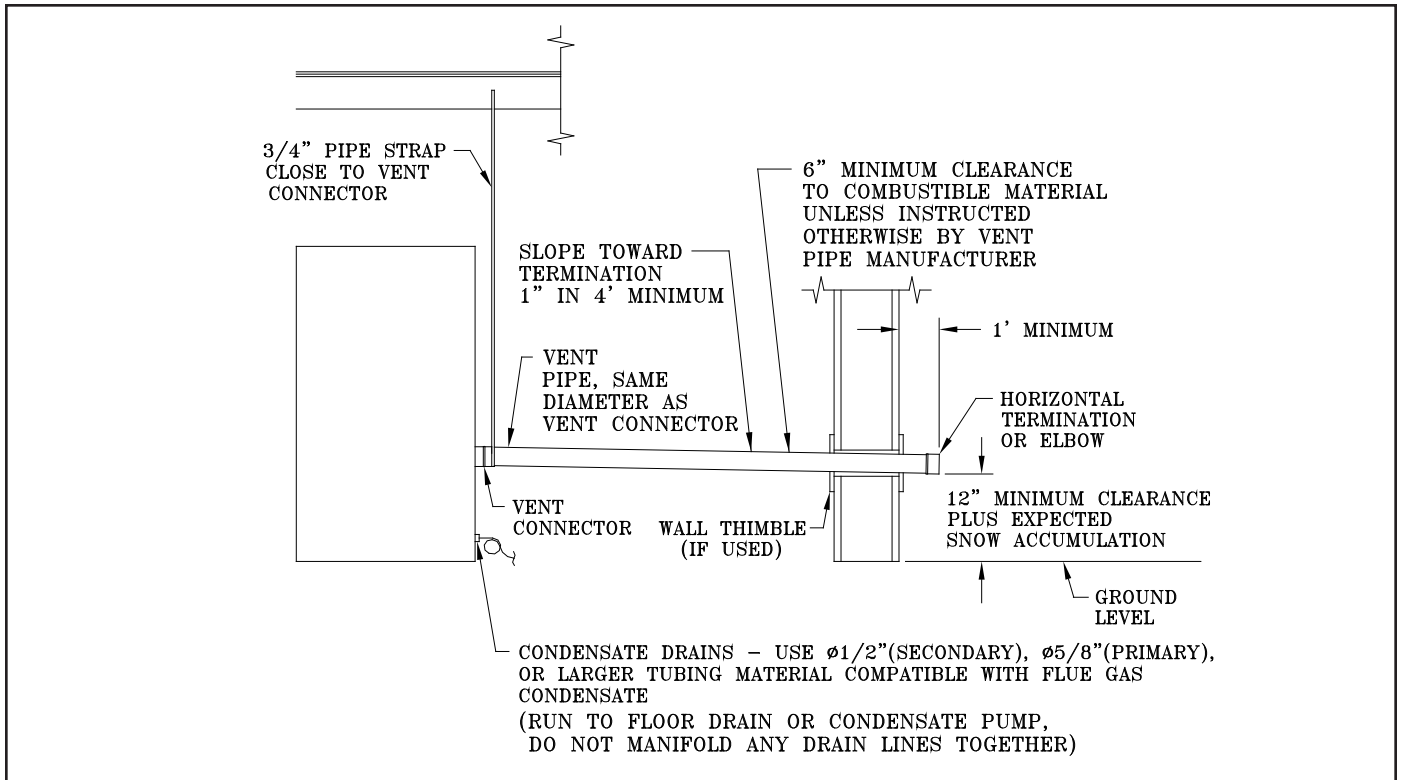

Figure 2: Typical Sidewall Pressurized Venting

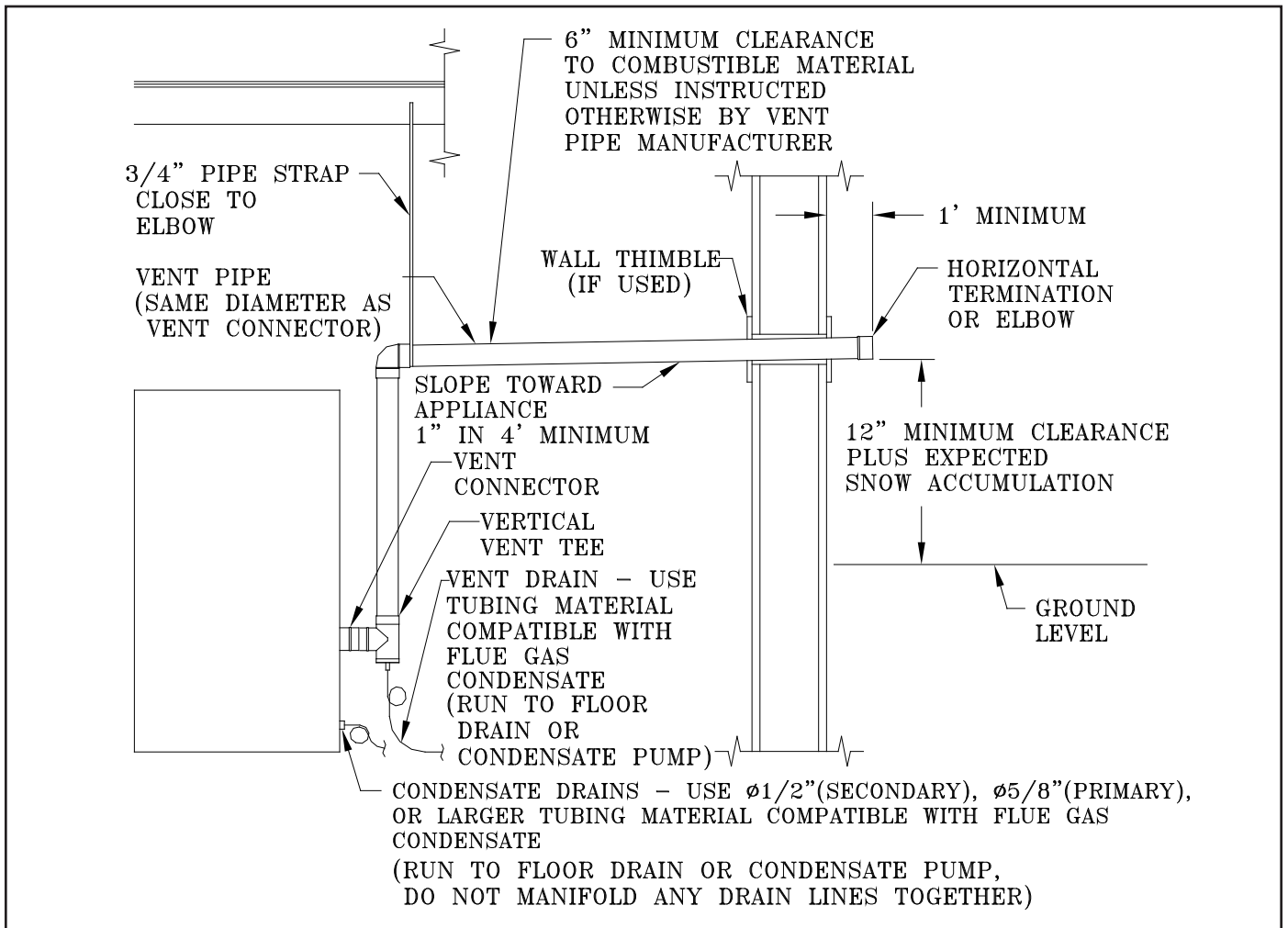

Figure 3: Typical Sidewall Pressurized Venting (Optional)

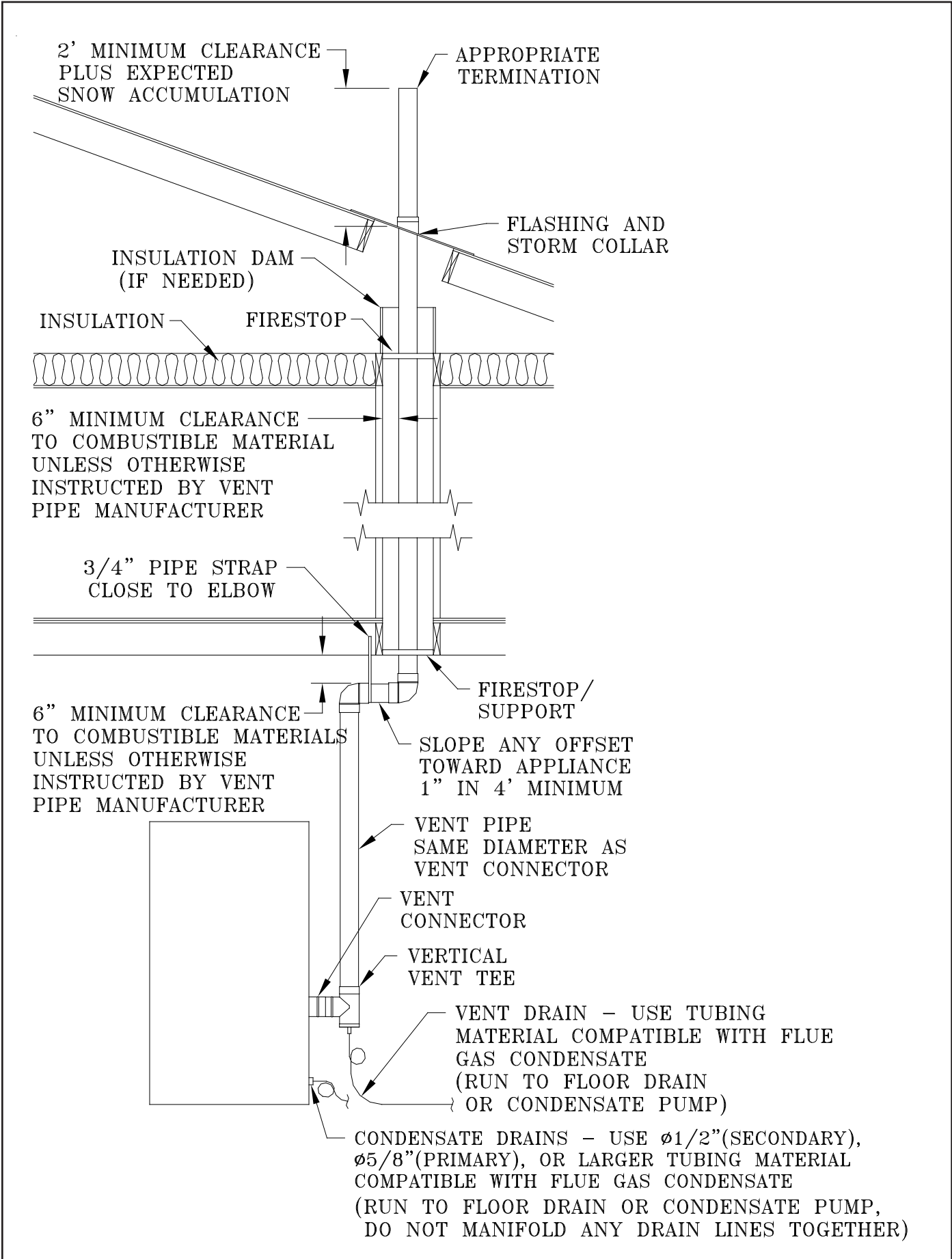

Figure 4: Typical Vertical Pressurized Venting

B. COMBUSTION AIR - See Figures 5 and 6

1. The boiler may be operated with inside or outside air.
2. Refer to combustion air piping drawings in this section of this manual for proper outside air installation details.
3. Combustion air conduit can be galvanized smoke pipe, PVC, CPVC, or flexible aluminum conduit.
4. The maximum air inlet length is fifty (50) equivalent feet. Air inlet length is equal to the total length of straight pipe plus the equivalent length of fittings. Consult conduit manufacturer for equivalent length of fittings and pipe.
5. Consult intake pipe manufacturer's instructions for proper method of sealing vent pipe sections and fittings. Do not use other adhesives or sealants except as expressly permitted by the vent pipe manufacturer's instructions.

WARNING

Do not reduce size of air intake pipe.

Read, understand and follow combustion air instruction restrictions contained in the Pre-Installation instructions of this manual.

6. Air intake termination must be located at least twelve (12) inches above grade plus the expected snow accumulation.
7. Boiler may be installed with vertical venting and sidewall combustion air inlet or visa versa.
8. The air intake pipe must be adequately supported with straps or supports no less than five (5) feet apart. The completed air intake pipe system must be rigid and able to withstand impacts without collapse.

CAUTION

Dirty, contaminated or dusty air used for combustion will decrease the useful life of the boiler air filter. Use outside air if inside air quality is questionable. Use outside air if the boiler is installed in manufacturing plants, laundries, dry cleaners or other locations with heavy particulates in the air.

WARNING

Do not locate air intake where petroleum distillates, CFCs, detergents, volatile vapors or any other chemicals are present. Severe boiler corrosion and failure will result. Thermal Solutions does not warrant failures caused by contaminated air.

Do not locate air intake termination where natural convection or wind conditions may cause the boiler exhaust gases to be drawn into the air intake.

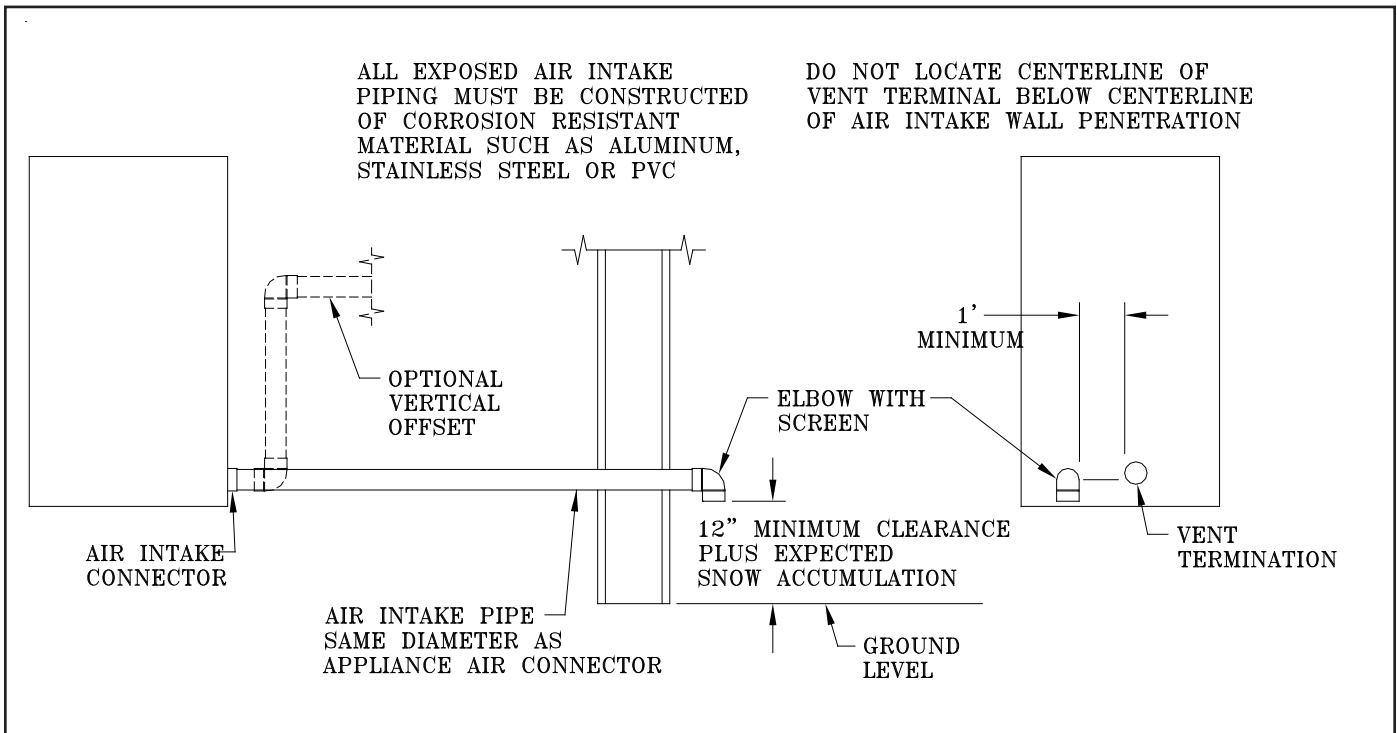

Figure 5: Horizontal Air Intake Piping

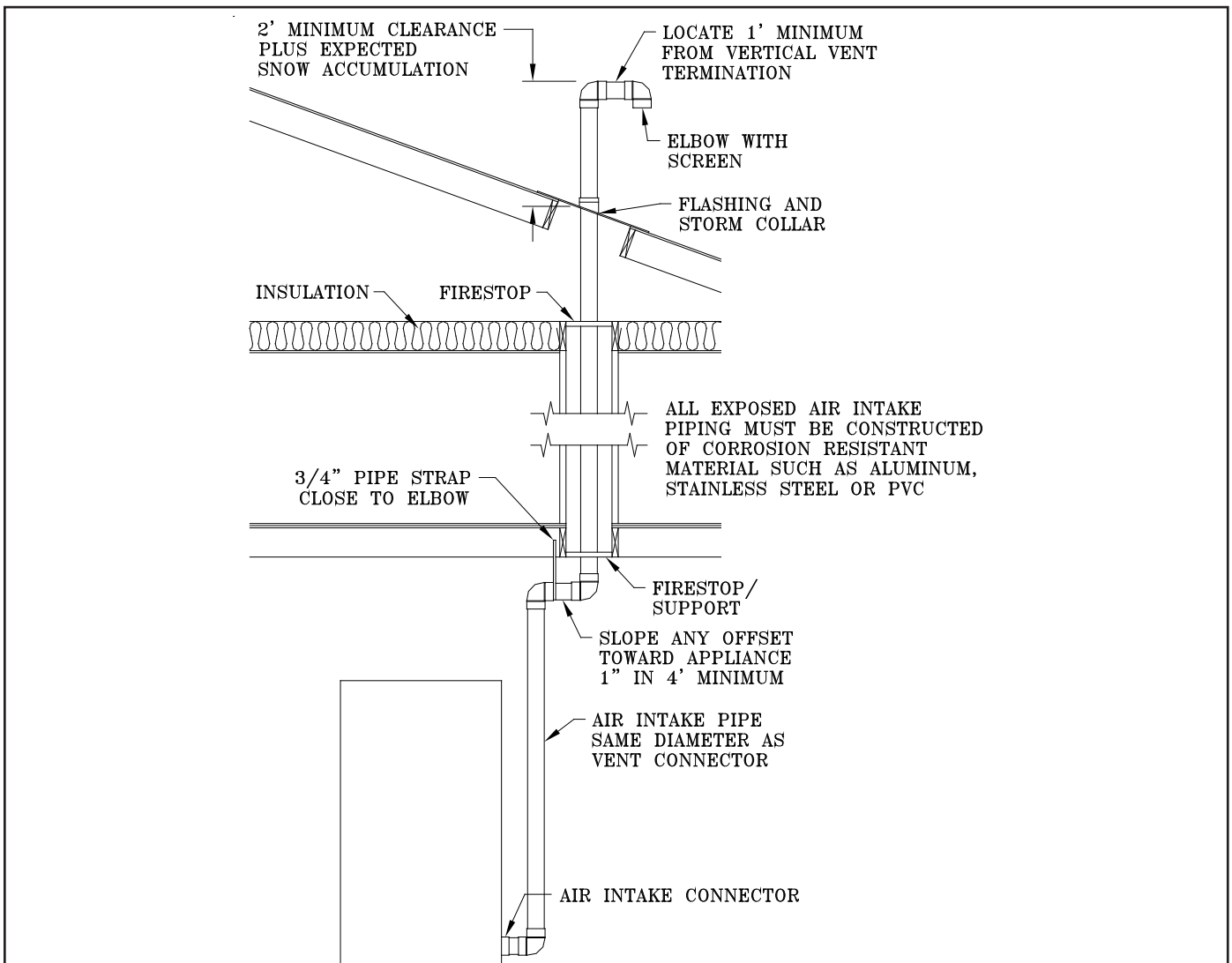

Figure 6: Vertical Air Intake Piping

C. WATER TREATMENT

The quality of water used in the heating system is essential for the successful operation and longevity of the system components. A successful water treatment plan will help to maintain efficiency, reduce the regularity of repair and/or replacement, and extend the working life of the boiler and other system equipment. If left untreated, poor water quality could cause a number of problems including, but not limited to, oxidation, scaling, corrosion, and fouling. See Table 1A for examples of typical chemical agents found in untreated water along with their potential effects.

Table 1A: Chemical Agents and Effects	
Compound	Effect
Calcium Carbonate (CaCO ₃)	Soft Scale
Calcium Bicarbonate (CaHCO ₃)	Soft Scale, CO ₂
Calcium Sulphate (CaSO ₄)	Hard Scale
Calcium Chloride (CaCl ₂)	Corrosion
Magnesium Carbonate (MgCO ₃)	Soft Scale
Magnesium Bicarbonate (MgHCO ₃)	Corrosion, Scale
Magnesium Sulphate (MgSO ₄)	Corrosion
Silicon Dioxide (SiO ₂)	Hard Scale

Since the condition of water varies from location to location, it is impossible to prescribe a one-size-fits-all treatment plan for the system water. In order to develop an effective water treatment plan, it will be necessary to gain knowledge of the impurities dissolved in the water. Once all the impurities are identified, the proper treatment plan can be established. Therefore, it will be essential to obtain the expertise of a qualified industrial water treatment professional for establishing a treatment plan.

In addition, a periodic testing/sampling plan should be developed. The intent of the plan should be to: (1) ensure the protection of the boiler and system equipment, (2) prevent an unforeseen system failure, (3) provide information for use in addressing the water quality, and (4) to confirm the proper concentration of chemicals in use.

CAUTION

The water shall have a maximum water hardness of 8.5 grains or 150 ppm. The recommended pH range is 8.8 to 9.2. However, other aspects of water quality can affect boiler operation and longevity. A qualified water treatment expert should be consulted to develop a complete water treatment plan.

Oxygen contamination of boiler water will cause corrosion of iron and steel boiler components, and can lead to boiler failure. Thermal Solutions Standard Warranty does not cover problems caused by oxygen contamination of boiler water.

Proper water treatment and boiler maintenance is required to avoid scale build-up on the inside of the boiler. Thermal Solutions Standard Warranty does not cover problems caused by scale build-up.

When using Glycol products, all Glycol manufacturers' requirements, including rust inhibitors, must be adhered. Max 50% Glycol.

WARNING

For EVCA 750-2000, the boiler air vent is shipped loose. Prior to connecting system piping to boiler, or filling the boiler with water, remove protective cap from the tagged elbow at the top of the loop piping. Install supplied air vent to boiler elbow using teflon tape.

CAUTION

Failure to properly pipe boiler may result in improper operation and damage to boiler or structure.

All piping, either new or existing, must be cleaned with a tri sodium (TSP) solution to remove mill scale and oils from the system. Failure to do so could result in premature failure of the heat exchanger (not covered by Thermal Solutions warranty).

On an existing or retrofit system, a filter or strainer must be installed on the system return prior to the boilers.

When using Glycol products, all Glycol manufacturers' requirements, including rust inhibitors, must be adhered.

1. Design and install boiler and system piping to prevent oxygen contamination of boiler water and frequent water additions.
 - a. There are many possible causes of oxygen contamination such as:
 - i. Addition of excessive make-up water as a result of system leaks.
 - ii. Absorption through open tanks and fittings.
 - iii. Oxygen permeable materials in the distribution system.
 - b. In order to insure long product life, oxygen sources must be eliminated. This can be accomplished by taking the following measures:
 - i. Repairing system leaks to eliminate the need for addition of make-up water.
 - ii. Eliminating and/or repairing fittings which allow oxygen absorption.
 - iii. Using of non-permeable materials in the distribution system.
 - iv. Isolating the boiler from the system water by installing a heat exchanger.
 - v. Using properly designed and operating air elimination devices in water piping.

CAUTION

Support weight of system piping adequately. Boiler loop piping is not designed to support system piping weight.

2. Connect system supply and return piping to boiler.
 - a. Refer to Figure 8.
 - b. Consult I=B=R Installation and Piping Guides.
 - c. Maintain ½" minimum distance between water piping and combustible material.
 - d. Consult Thermal Solutions for unusual system requirements.
3. Remove protective cap from boiler drain line located in the rear of the boiler (EVCA-750 through 2000) or the right side of the boiler (EVCA-3000).
4. For EVCA-3000, install a 10" minimum or longer 1" diameter nipple into hole in right side of base and thread into drain elbow underneath the boiler.
5. Install drain valve in the boiler drain line at bottom rear or right side of the boiler.
6. If this boiler is used in connection with refrigeration systems, the boiler must be installed so that the chilled medium is piped in parallel with the boiler using appropriate valves to prevent the chilled medium from entering the boiler. Also consult I=B=R Installation and Piping Guides. If this boiler is connected to heating coils located in air handling units where they may be exposed to refrigerated air, the boiler piping must be equipped with flow control valves to prevent gravity circulation of boiler water during operation of the cooling system.
7. Install optional low water cut-off in system piping above the boiler, if not shipped with boiler. On EVCA-750 through -2000 boilers, a low water cut-off may be installed on the boiler at the factory as an option. A factory-mounted low water cut-off is standard on all EVCA-3000 boilers.
8. Install an air eliminating device to remove air from the system.

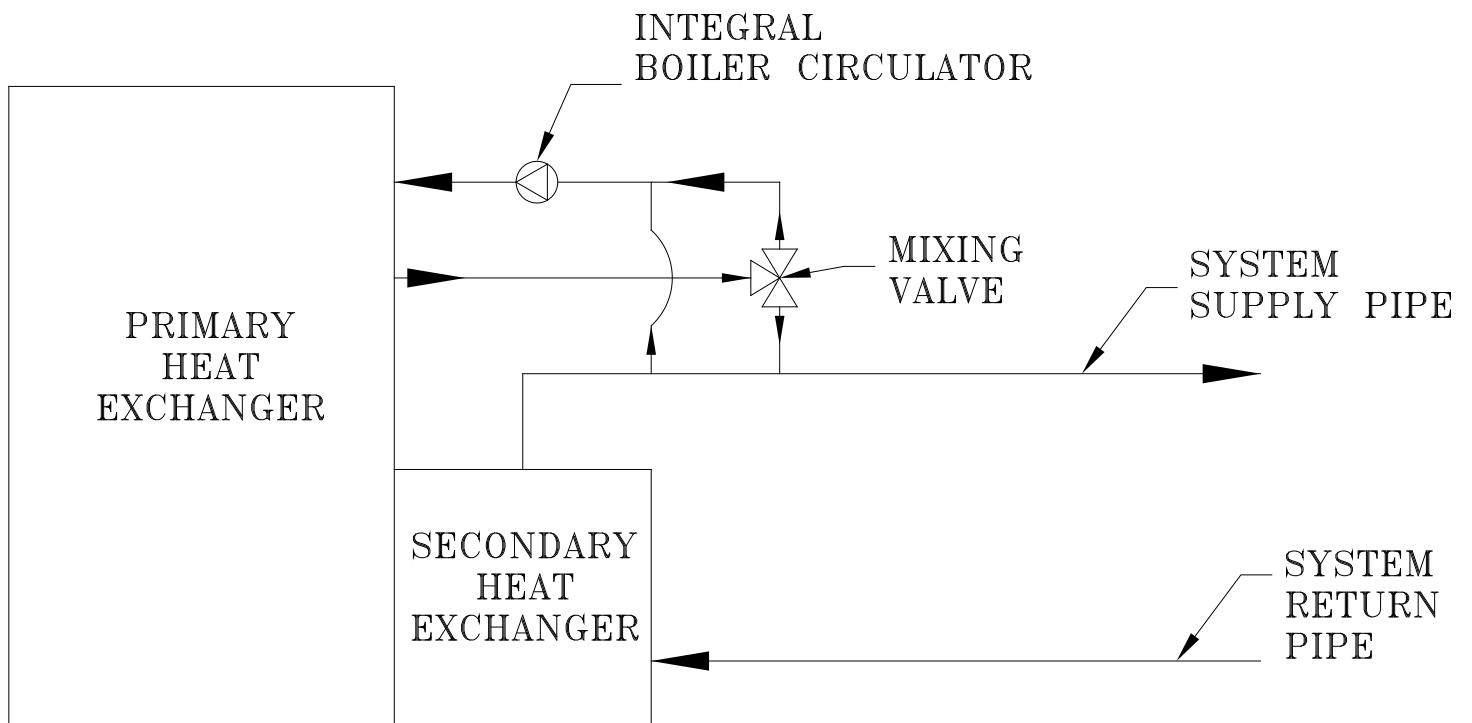

Figure 8: Schematic Boiler Piping

WARNING

Failure to operate the unit with the proper water flow rate can lead to appliance failure. Always verify proper water flow switch operation so that the unit stops operating if improper water flow is present.

Safety relief valve discharge piping must be piped such that the potential of severe burns is eliminated. DO NOT pipe in any area where freezing could occur. DO NOT install any shut-off valves, plugs or caps. Consult Local Codes for proper discharge piping arrangement.

If a high head system pump is installed, ensure that the boiler relief valve and system piping are capable of operating properly at the combined pressure of the system fill pressure plus the pump static head pressure.

Do not install valves, plugs or caps in safety relief valve piping.

Safety relief valve piping must be terminated such that in the event the safety relief valve opens, the discharge will not cause personal injury or damage.

Do not operate the boiler with flow rates in excess of the maximum flow rates listed in Table 1B. Tube erosion and pitting will occur. Thermal Solutions Standard Warranty does not cover problems caused by excessive water flow rates.

11. The factory supplied circulator is not intended to replace the boiler supply circulator or the system supply circulator. It provides a constant flow to the primary heat exchanger.
12. If the boiler is installed in a closed water supply system, such as one having a back flow preventer in the cold water supply line, means shall be provided to control thermal expansion. Contact the water supplier or local plumbing inspector on how best to control this situation.
13. A pressure relief valve is supplied with each boiler. No valve is to be placed between the relief valve and appliance.
 - a. Pipe the safety relief discharge to a suitable place for disposal when relief occurs.
 - b. Do not install reducing couplings or other restrictive devices in the safety relief discharge line.
 - c. The safety relief discharge line must allow for complete drainage of both the valve and line.
14. If the relief valve discharges periodically, this may be due to thermal expansion in a closed water supply system. Contact the water supplier or local plumbing inspector on how to correct this situation. **DO NOT PLUG THE RELIEF VALVE.**

9. Refer to Table 1B for pressure drop, flow rates, and temperature rise across the heat exchanger (ΔT s).
10. If an EVCA boiler is installed in a non-condensing heating application, where return water temperatures are 130°F or higher, system flow rates creating delta-Ts greater than 40°F may cause nuisance shutdowns due to inadequate flow to the boiler's flow switch. If an EVCA is to be operated in non-condensing conditions, the maximum recommended delta-T shall be 40°F.

Table 1B- EVCA BOILER FLOW AND PRESSURE DROP

BOILER MODEL	*20°F ΔT		30°F ΔT		40°F ΔT		50°F ΔT		60°F ΔT		70°F ΔT	
	ΔP (Ft. hd)	GPM	ΔP (Ft. hd)	GPM	ΔP (Ft. hd)	GPM	ΔP (Ft. hd)	GPM	ΔP (Ft. hd)	GPM	ΔP (Ft. hd)	GPM
EVCA-750	32.4	70	17.8	47	11.6	35	8.3	28	6.3	23	5.0	20
EVCA-1000	36.9	94	20.9	63	13.9	47	10.2	38	7.9	31	6.4	27
EVCA-1500	53.7	142	27.3	95	16.9	71	11.7	57	8.6	47	6.7	41
EVCA-2000	67.8	190	36.0	127	23.0	95	16.2	76	12.2	63	9.6	54
EVCA-3000	29.2	291	15.2	194	9.6	146	6.7	116	5.0	97	3.9	83

Note: * Indicates maximum allowable flow rate.

E. GAS PIPING

WARNING

Failure to properly pipe gas supply to boiler may result in improper operation and damage to the boiler or structure. Always assure gas piping is absolutely leak free and of the proper size and type for the connected load.

An additional gas pressure regulator may be needed. Consult gas supplier.

1. Size gas piping. Design system to provide adequate gas supply to boiler. Consider these factors.
 - a. Allowable pressure drop from point of delivery to boiler. Refer to Table 2 for minimum and maximum boiler gas train inlet pressure. If gas supply pressure is higher than maximum as listed in Table 2, an additional field supplied pressure regulator will be required.

TABLE 2 - BOILER GAS TRAIN INLET PRESSURE		
BOILER MODEL	MODULATION	
	MIN ("w.c.)	MAX (psig)
EVCA-750	7.0	5
EVCA-1000	7.0	5
EVCA-1500	7.0	5
EVCA-2000	9.0	5
EVCA-3000	6.0	5

- b. If a lower minimum gas pressure is needed, the low gas pressure build can be used. The minimum gas pressure on all of the low gas pressure builds is 4.0 in. w.c. Consult factory if this option is desired. This option is not available on the EVCA-3000.
 - c. Maximum gas demand. Table 6 lists boiler input rate. Also consider existing and expected future gas utilization equipment (i.e., water heater, cooking equipment).
 - d. Length of piping and number of fittings. Refer to Table 3 for maximum capacity of schedule 40 pipe. Table 5 lists equivalent pipe length for standard fittings.
 - i. Given the specific gravity of gas at your location, a correction factor can be found on Table 4 and multiplied by the "Capacity in Cubic Feet of gas Per Hour" on Table 3.
 - ii. For gas piping material other than schedule 40 pipe, refer to the National Fuel Gas Code, NFPA 54/ANSI Z223.1 and/or CAN/CGA B149 Installation codes.
2. If step down regulator is required, it must be used in conjunction with the factory supplied regulator and

be located as far away from the boiler as possible to prevent nuisance shutdowns.

- a. The minimum and maximum inlet gas pressure must not exceed the value specified in Table 2.
3. Install field supplied sediment trap, ground-joint union and manual non-displaceable shut-off valve upstream of factory supplied shut-off valve outside the boiler jacket. Use methods and materials in accordance with Local Codes and requirements of gas supplier. In absence of such requirements, follow National Fuel Gas Code, NFPA 54/ANSI Z223.1 and/or CAN/CGA B149 Installation Codes.
4. Use thread joint compound resistant to the action of liquefied petroleum gas.

WARNING

Failure use proper thread compounds on all gas connectors may result in leaks of flammable gas.

5. All above ground gas piping upstream from field supplied manual gas valve must be electrically continuous and bonded to a grounding electrode. Do not use gas piping as grounding electrode. Refer to National Electrical Code, ANSI/NFPA 70 and /or CSA C22.1 Electrical Codes.

WARNING

Gas supply to boiler and system must be absolutely shut off prior to installing or servicing boiler gas piping.

WARNING

Use an additional gas pressure regulator where the gas pressure is greater than 5 psig. Using one additional regulator for multiple boilers may result in unsafe boiler operation. The additional regulator must be able to properly regulate gas pressure flow at the lowest input of a single boiler. If the regulator cannot do this, two or more additional regulators are required. Consult regulator manufacturer's instructions for minimum gas flow rate.

NOTICE

The EVCA-3000 is shipped with the gas line regulator in the downward position. During installation loosen the union behind the regulator and rotate gas inlet to horizontal orientation. Remove cap and reattach 1/4" regulator tubing to regulator.

6. Pressure test. The boiler and its gas connection must be leak tested before placing boiler in operation.
- Protect boiler gas control valve. For all testing over ½ psig, boiler and its individual shutoff valve must be disconnected from gas supply piping. For testing at ½ psig or less, isolate boiler from gas supply piping by closing the boiler's individual manual shutoff valve.
 - Locate leaks using approved combustible gas detector, soap and water, or similar nonflammable solution.

DANGER

Do not use matches, candles, open flames or other ignition source to check for leaks.

**TABLE 3: MAXIMUM GAS CAPACITY OF SCHEDULE 40 PIPE.
(Based on Gas Pressure less than 2 psi, pressure drop of 0.3 in w.c. and 0.6 specific gravity.)**

Pipe Length in Equivalent Feet	Pipe Size (in.)							
	3/4	1	1-1/4	1-1/2	2	2-1/2	3	4
	Capacity in Cubic Feet of Gas Per Hour							
10	273	514	1060	1580	3050	4860	8580	17500
20	188	353	726	1090	2090	3340	5900	12000
30	151	284	583	873	1680	2680	4740	9660
40	129	243	499	747	1440	2290	4050	8270
50	114	215	442	662	1280	2030	3590	7330
60	104	195	400	600	1160	1840	3260	6640
70	95	179	368	552	1060	1690	3000	6110
80	89	167	343	514	989	1580	2790	5680
90	83	157	322	482	928	1480	2610	5330
100	79	148	304	455	877	1400	2470	5040
125	70	131	269	403	777	1240	2190	4460
150	63	119	244	366	704	1120	1980	4050
175	58	109	224	336	648	1030	1820	3720
200	54	102	209	313	602	960	1700	3460

**TABLE 4 – SPECIFIC GRAVITY
CORRECTION FACTORS**

Specific Gravity	Correction Factor	Specific Gravity	Correction Factor
0.50	1.10	1.10	0.74
0.55	1.04	1.20	0.71
0.60	1.00	1.30	0.68
0.65	0.96	1.40	0.66
0.70	0.93	1.50	0.63
0.75	0.90	1.60	0.61
0.80	0.87	1.70	0.59
0.85	0.84	1.80	0.58
0.90	0.82	1.90	0.56
1.00	0.78	2.00	0.55

TABLE 5 - EQUIVALENT OF STANDARD PIPE FITTING & VALVES

Pipe Size	I.D. Inches	Valves Fully Open (Screwed, Flanged, Welded)			Schedule 40, Screwed Fittings			
		Gate	Globe	Angle	Swing Check	90° Elbow (threaded)	45° Elbow (threaded)	90° Tee, Flow through Branch (threaded)
1/2"	0.622	0.36	17.3	8.65	4.32	1.55	0.73	3.10
3/4"	0.824	0.48	22.9	11.4	5.72	2.06	0.96	4.12
1"	1.049	0.61	29.1	14.6	7.27	2.62	1.22	5.24
1-1/4"	1.380	0.81	38.3	19.1	9.58	3.45	1.61	6.90
1-1/2"	1.610	0.94	44.7	22.4	11.2	4.02	1.88	8.04
2"	2.067	1.21	57.4	28.7	14.4	5.17	2.41	10.3
2-1/2"	2.469	1.44	68.5	34.3	17.1	6.16	2.88	12.3
3"	3.068	1.79	85.2	42.6	21.3	7.67	3.58	15.3
4"	4.026	2.35	112	56	28.0	10.1	4.70	20.2
6"	6.065	3.54	168	84.1	42.1	15.2	7.07	30.4

Equivalent lengths are for standard screwed fittings and for screwed, flanged, or welded valves relative to schedule 40 steel pipe.

WARNING

Table 6 lists gas inputs at sea level to 2000 feet altitude. Reduce gas input four percent (4%) for each additional 1000 feet above sea level.

TABLE 6: RATED INPUT

BOILER MODEL	RATED CAPACITY (CFH)		GAS CONNECTION SIZE (inch dia.)
	NATURAL	LP/PROPANE	
EVCA-750	750	300	1
EVCA-1000	1000	400	1-1/2
EVCA-1500	1500	600	1-1/2
EVCA-2000	2000	800	1-1/2
EVCA-3000	3000	1200	2

F. ELECTRICAL

1. General. Install wiring and ground boiler in accordance with authority having jurisdiction or in absence of such requirements National Electrical Code, ANSI/NFPA 70 and/or CSA C22.1 Electrical Code.

WARNING

Failure to properly wire electrical connections to the boiler may result in serious physical harm. DO NOT ATTACH ADDITIONAL J-Box to back or top of boiler jacket.

DANGER

Positively assure all electrical connections are unpowered before attempting installation or service of electrical components or connections of the boiler or building. Lock out all electrical boxes with padlock once power is turned off.

2. A separate electrical circuit must be run from the main electrical service with an over-current device/disconnect in the circuit. A service switch is recommended and may be required by some local jurisdictions. Locate the service switch such that the appliance can be shut off without exposing personnel to danger in the event of an emergency.
3. Connect the main power supply and ground from fused disconnect to proper boiler electrical leads located in the junction box at the rear of the boiler. Refer to electrical consumption plate on boiler jacket.
4. Protection for the factory installed circulator is provided by the factory. Install a separate fused disconnect switch for each additional circulator installed (i.e. boiler and system circulators).
5. Connect field supplied safety limits or devices using proper terminals provided in boiler electrical cabinet. Refer to wiring diagram supplied with boiler for wiring information. Refer to Figures 9a - 9f for typical wiring diagrams. Refer to Figure 1, for electrical requirements for boiler.

CAUTION

Each boiler must be protected with a dedicated properly sized fused disconnect.

WARNING

Electrical power may be supplied from more than one service. Make sure all power is off before attempting any electrical work.

The wiring diagrams contained in this manual are for reference purposes only. Each boiler may be wired differently according to the specifications given to Thermal Solutions at the time the boiler was purchased. Always use the wiring diagram provided with the boiler. If the wiring diagram provided with the boiler is unavailable, STOP all wiring work and contact Thermal Solutions for a replacement diagram.

Do not directly connect low voltage (24 volt, milliamp, etc.) controls to this boiler. If low voltage controls are desired, isolating relays must be used.

Never jump out any safety controls.

Never jump out or make inoperative any safety or operating controls. Each boiler must be protected with a properly sized over-circuit device.

6. The following pages have sample wiring diagrams. Contact Thermal Solutions Representative or visit website (www.thermalsolutions.com) for current wiring options.
7. An as-built wiring diagram is included with every boiler when it ships.

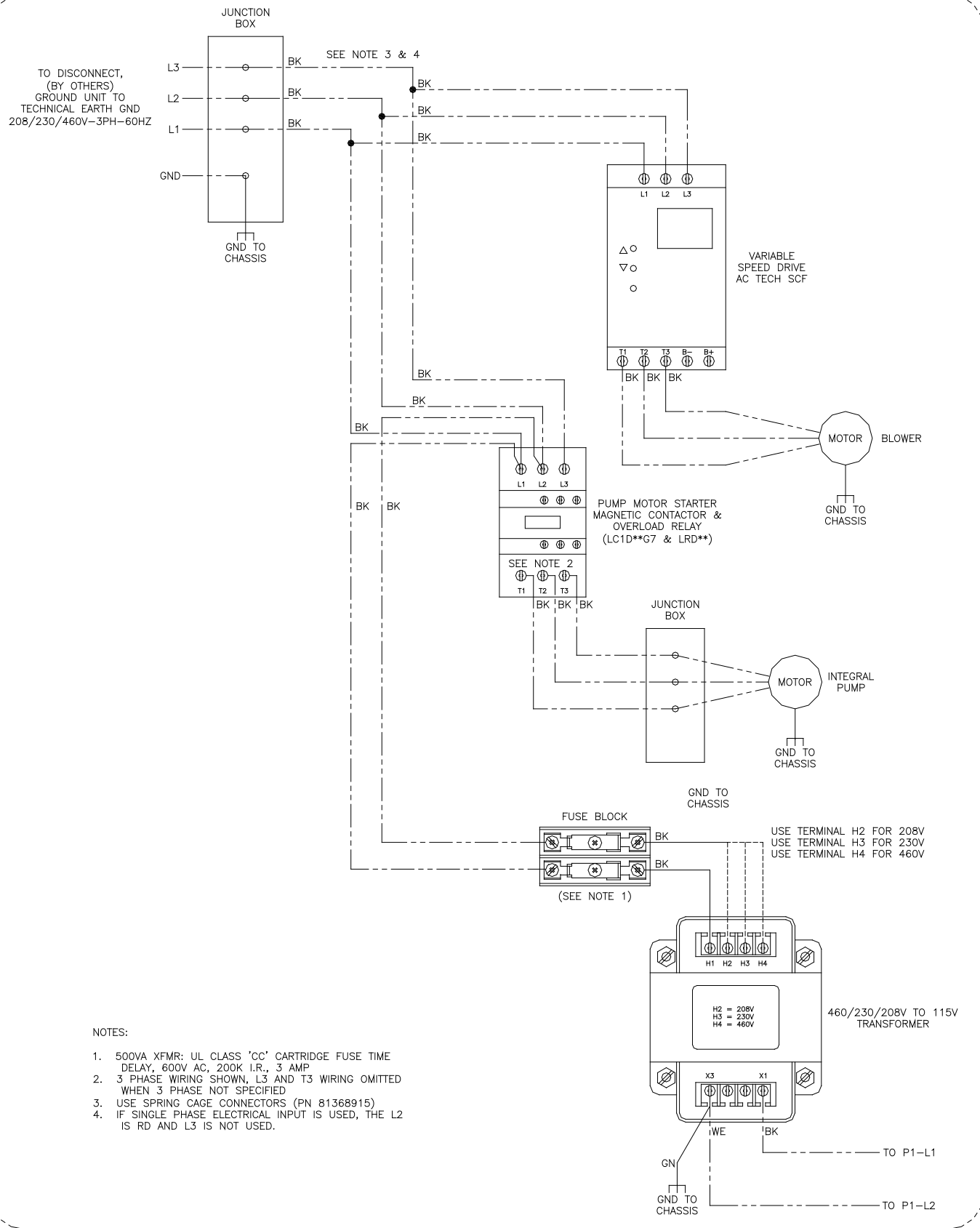

Figure 9a: 208/230/480V - 1PH/3PH - 60HZ Supply Power Wiring Schematic

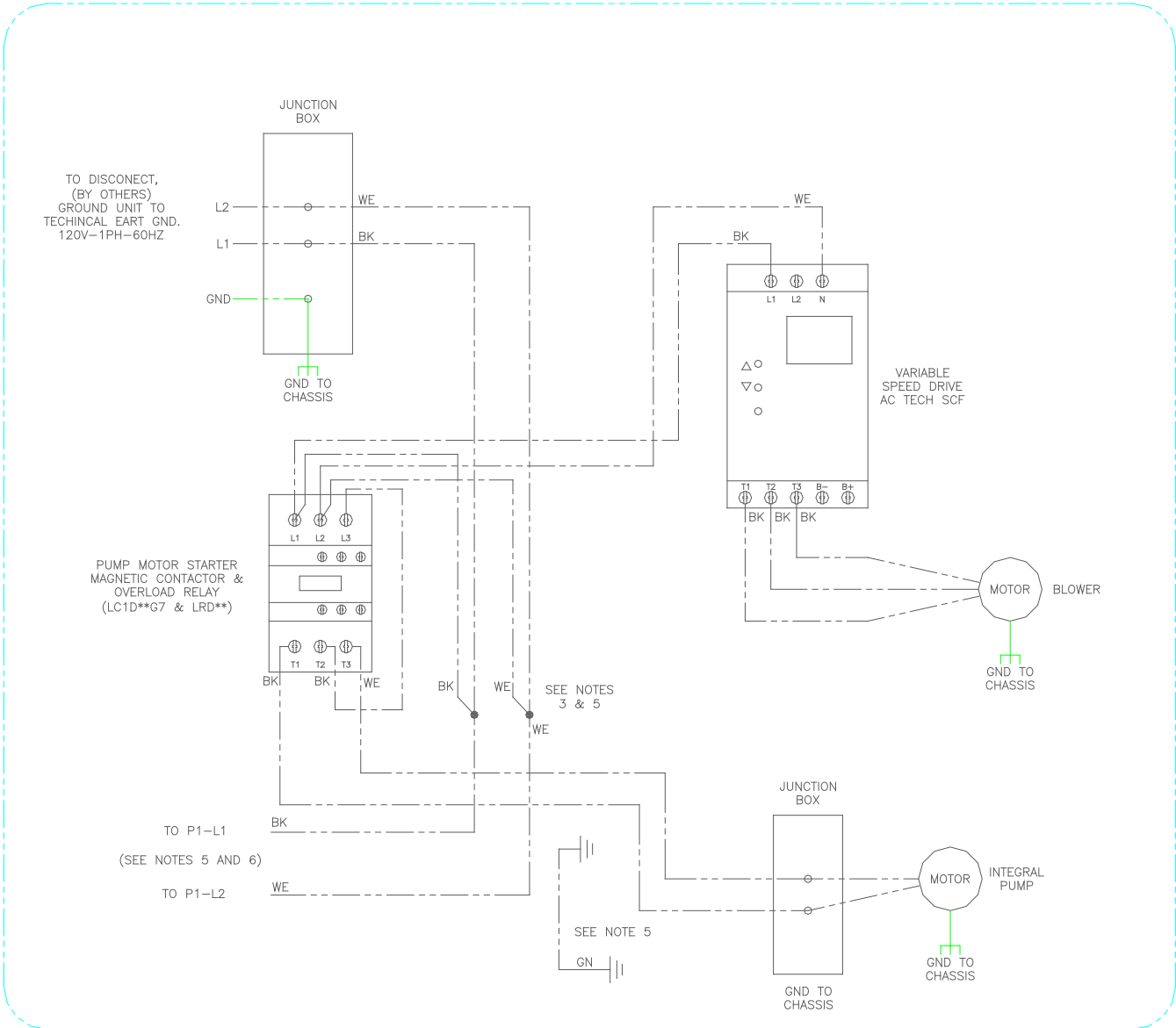
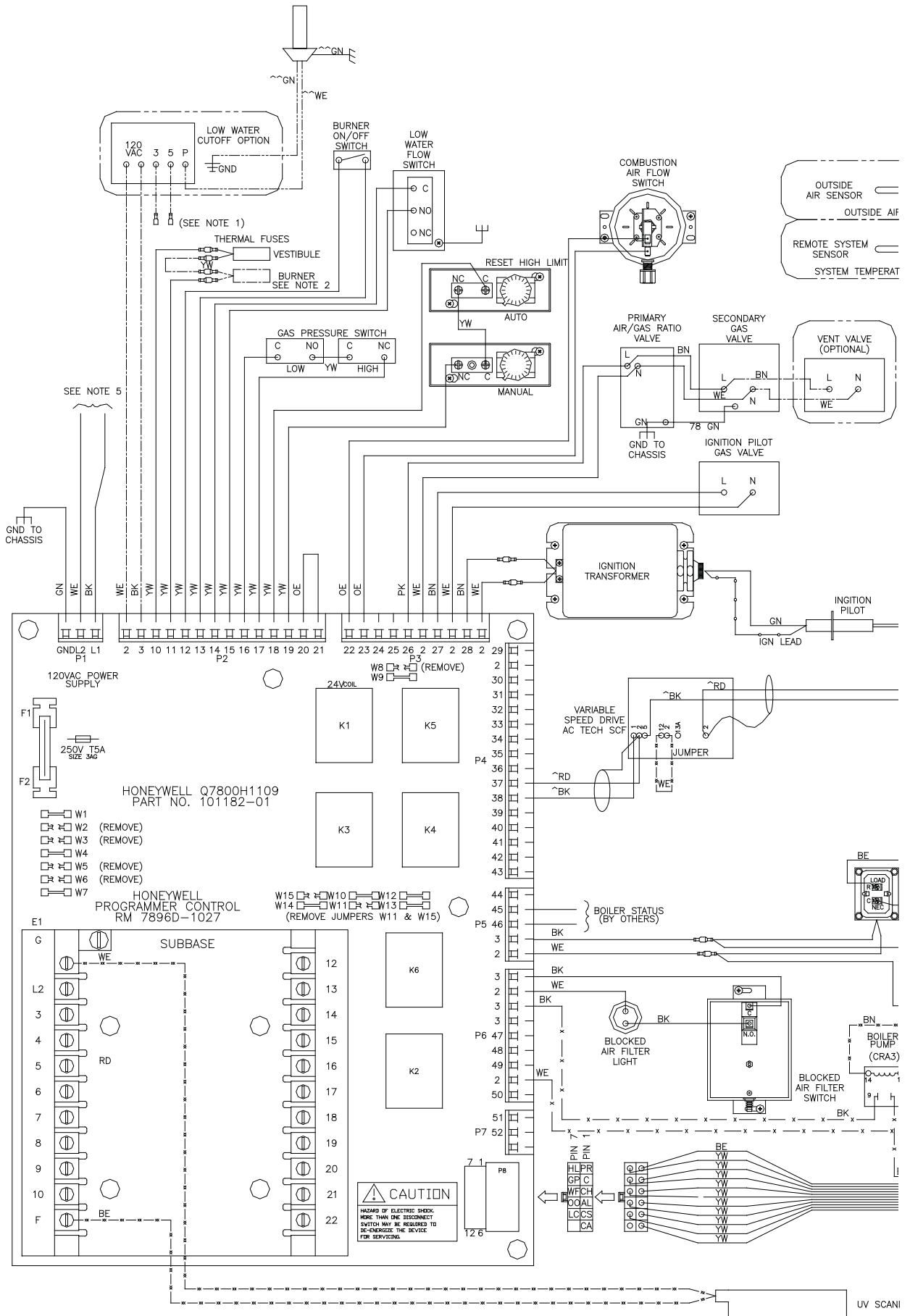

Figure 9b: 120V - 1PH - 60HZ Supply Power Wiring Schematic

Figure 9c: Control Wiring Schematic (EVCA-750/2000)



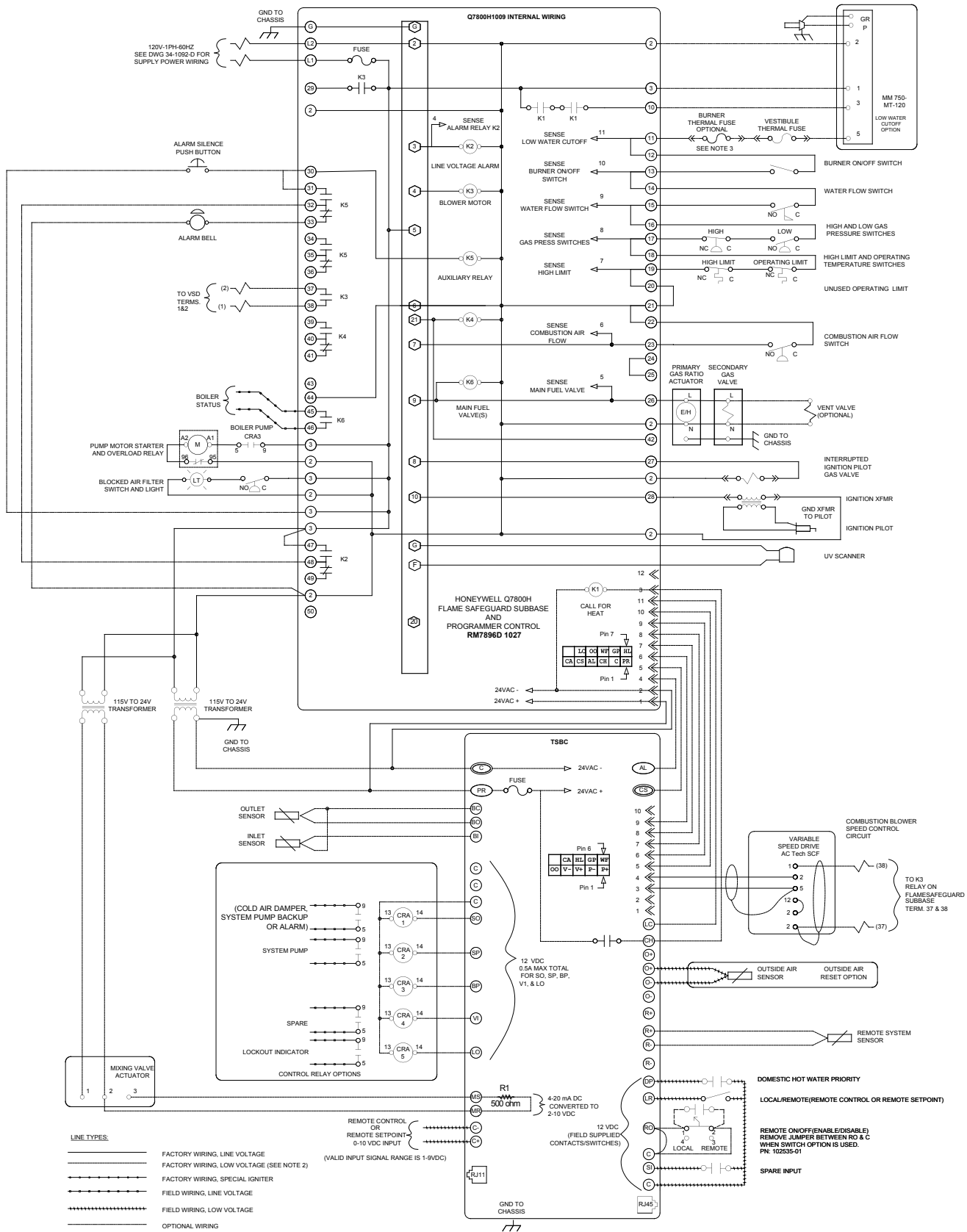
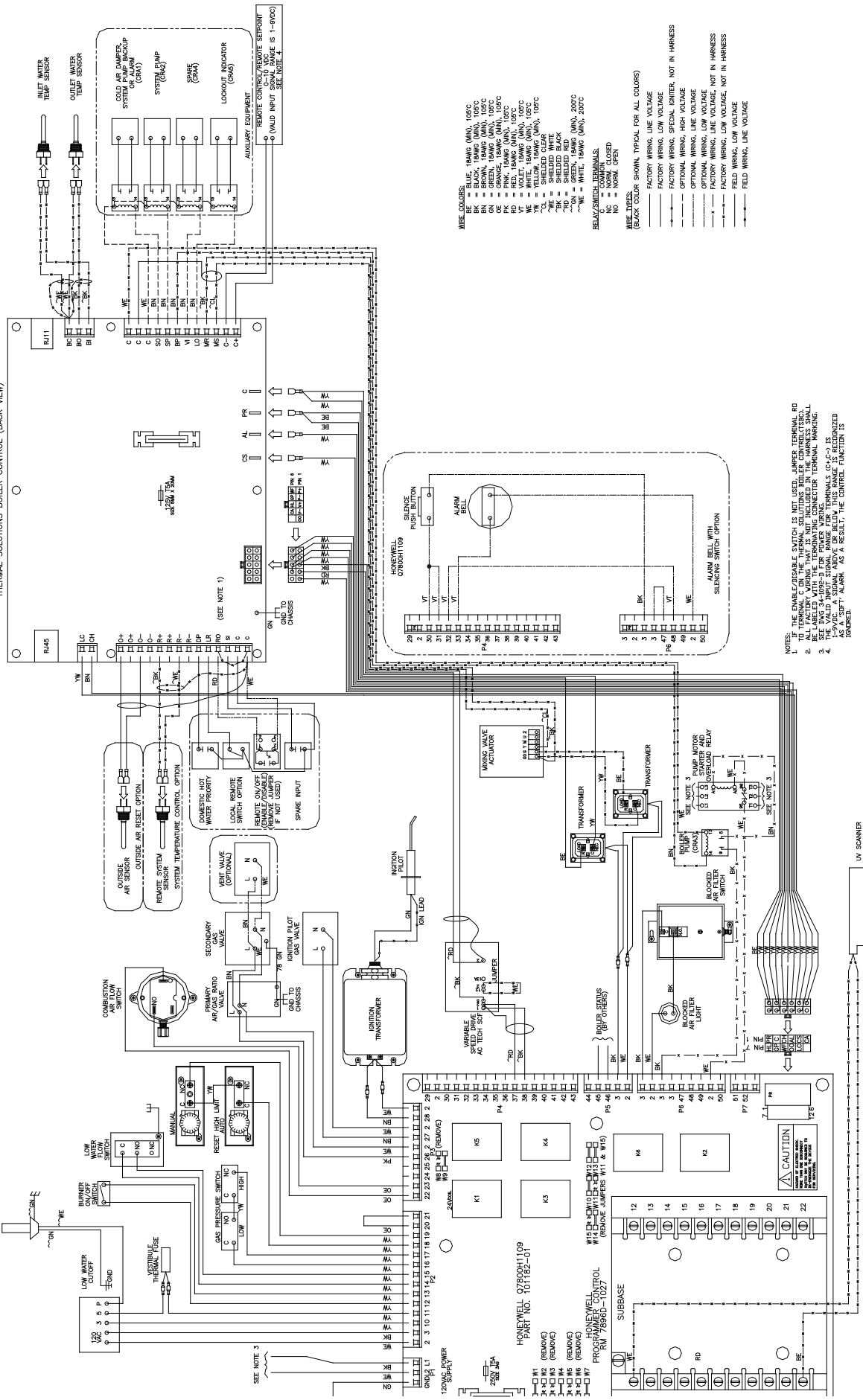

Figure 9d: Ladder Wiring Diagram (EVCA-750/2000)

THERMAL SOLUTIONS BOILER CONTROL (BACK VIEW)



- WIRE COLORS:**
- BL = BLACK, 15AWG (MIN), 105°C
 - BR = BROWN, 15AWG (MIN), 105°C
 - BN = BROWN, 18AWG (MIN), 105°C
 - OR = ORANGE, 15AWG (MIN), 105°C
 - PK = PINK, 15AWG (MIN), 105°C
 - VT = VIOLET, 15AWG (MIN), 105°C
 - YL = YELLOW, 15AWG (MIN), 105°C
 - YL = YELLOW, 18AWG (MIN), 105°C
 - ~L = SHIELDED CLEAR
 - ~RD = SHIELDED RED
 - ~BK = SHIELDED BLACK
 - ~W = WHITE, 15AWG (MIN), 200°C
 - NO = NORM OPEN
- RELAY/SWITCH TERMINALS:**
- NO = NORM OPEN
 - NC = NORM CLOSED
 - NO = NORM OPEN
- WIRE TYPES:**
- (BLACK COLOR SHOWN, TYPICAL FOR ALL COLORS)
 - FACTORY WIRING, LINE VOLTAGE
 - FACTORY WIRING, LOW VOLTAGE
 - FACTORY WIRING, SPECIAL ORDER, NOT IN HARNESS
 - OPTIONAL WIRING, LINE VOLTAGE
 - OPTIONAL WIRING, LOW VOLTAGE
 - FACTORY WIRING, LINE VOLTAGE, NOT IN HARNESS
 - FACTORY WIRING, LOW VOLTAGE, NOT IN HARNESS
 - FIELD WIRING, LINE VOLTAGE
 - FIELD WIRING, LOW VOLTAGE

- NOTES:**
1. IF THE ENABLE/DISABLE SWITCH IS NOT USED, JUMPER TERMINAL RD
 2. ALL FACTORY WIRING THAT IS NOT INCLUDED IN THE HARNESS SHALL
 3. SEE PAGE 34-102-3 FOR POWER WIRING
 4. THIS VALID PROGRAMMING FILE BELOW THIS RANGE IS RECOGNIZED AS A "SOFT" ALARM. AS A RESULT, THE CONTROL FUNCTION IS

Figure 9e: Control Wiring Schematic (EVCA-3000)

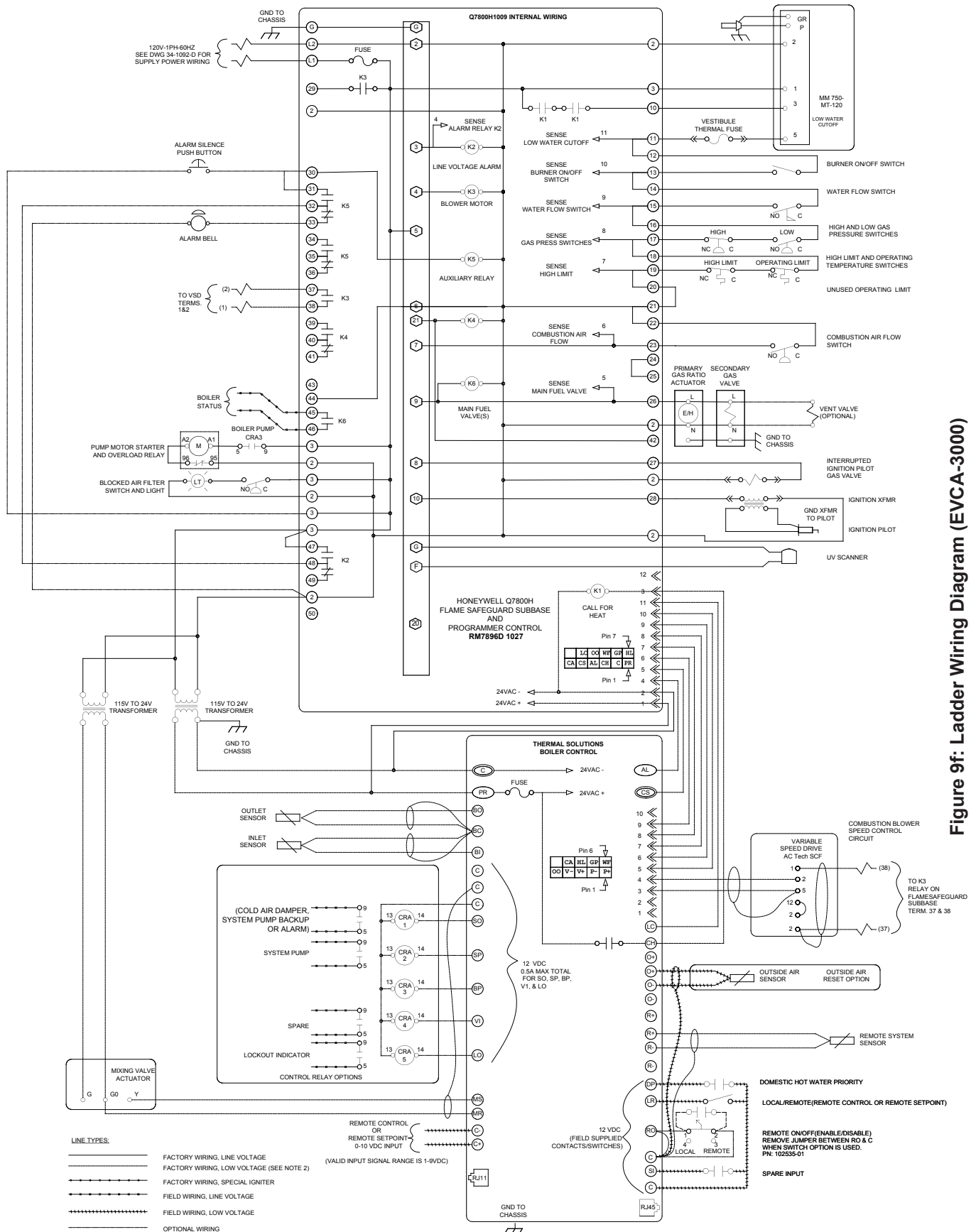

Figure 9f: Ladder Wiring Diagram (EVCA-3000)

G. MODULAR SYSTEMS

1. General Guidelines

- a. Read and follow all venting, combustion air, water piping, gas piping and electrical instructions contained in this manual unless otherwise instructed in this section.
- b. Modular systems are complex. Design and installation of modular systems should only be undertaken by skilled and knowledgeable engineers and contractors.
- c. Consult Local Building Codes, National Fuel Gas Code, or NFPA 54/ANSI Z223.1 for restrictions and instructions for modular boilers.
- d. Refer to the Pre-Installation section for further warnings, cautions, notices and instructions.

2. Module Sizing

Consult factory for recommended number and size of boilers for a given input.

3. Venting

- a. Refer to Venting Section for sidewall and vertical venting guidelines.
- b. Each boiler requires an individual vent pipe.
- c. The minimum horizontal distance between vent terminations is one (1) foot. Additional horizontal distance is desirable to avoid frost damage to the building. Vent terminations must be at least twelve (12) inches above the ground plus the expected snow accumulation.
- d. **IMPORTANT:** Refer to the Venting section for further warnings, cautions, notices and instructions.

4. Air Intake Piping

- a. Consult intake pipe manufacturer for common air intake pipe sizing.
- b. Refer to Figures 10 and 11 for common air intake guidelines for modular boilers.
- c. Individual air intake pipes may be used in lieu of common air intake piping.
- d. Common air intake straight lengths and fittings should be assumed to have the equivalent length the same as an individual air intake pipe, used for a given boiler intake pipe diameter.
- e. Position horizontal air intake termination center line below horizontal vent termination's center line.

- f. Vertical air intake pipe must terminate at least two (2) feet above the closest portion of the roof.

- g. **IMPORTANT:** Refer to the Combustion Air section for further warnings, cautions, notices and instructions.

5. Water Piping

- a. Refer to Figure 12 for typical water piping for a single boiler. Refer to Figures 13 through 15 or for typical water piping for modular boilers.
- b. Installing a low water cut-off in the system piping is highly recommended and may be required by Code, if not factory-mounted on boiler.
- c. Refer to Table 1b for pressure drop for each boiler.
- d. Consult I=B=R Installation and Piping Guide.
- e. Maintain ½" minimum distance between water piping and combustible material.
- f. Refer to Water Piping and Trim Section for further warnings, cautions, notices and instructions.

NOTICE

The pressure drop given in Table 1B is for the boiler only. The pressure drop of each system fitting and component must be added to the boiler pressure drop to determine the system pressure head requirement. See Table 5 for fitting and component equivalent lengths.

CAUTION

Proper water treatment is required. The water shall have a maximum water hardness of 8.5 grains or 150 ppm. The recommended pH range is 8.8 to 9.2.

6. Gas Piping

- a. Refer to National Fuel Gas Code, Local Codes and Tables 2 through 6 for gas pipe sizing.
- b. Refer to Gas Piping Section for further warnings, cautions, notices and instructions.

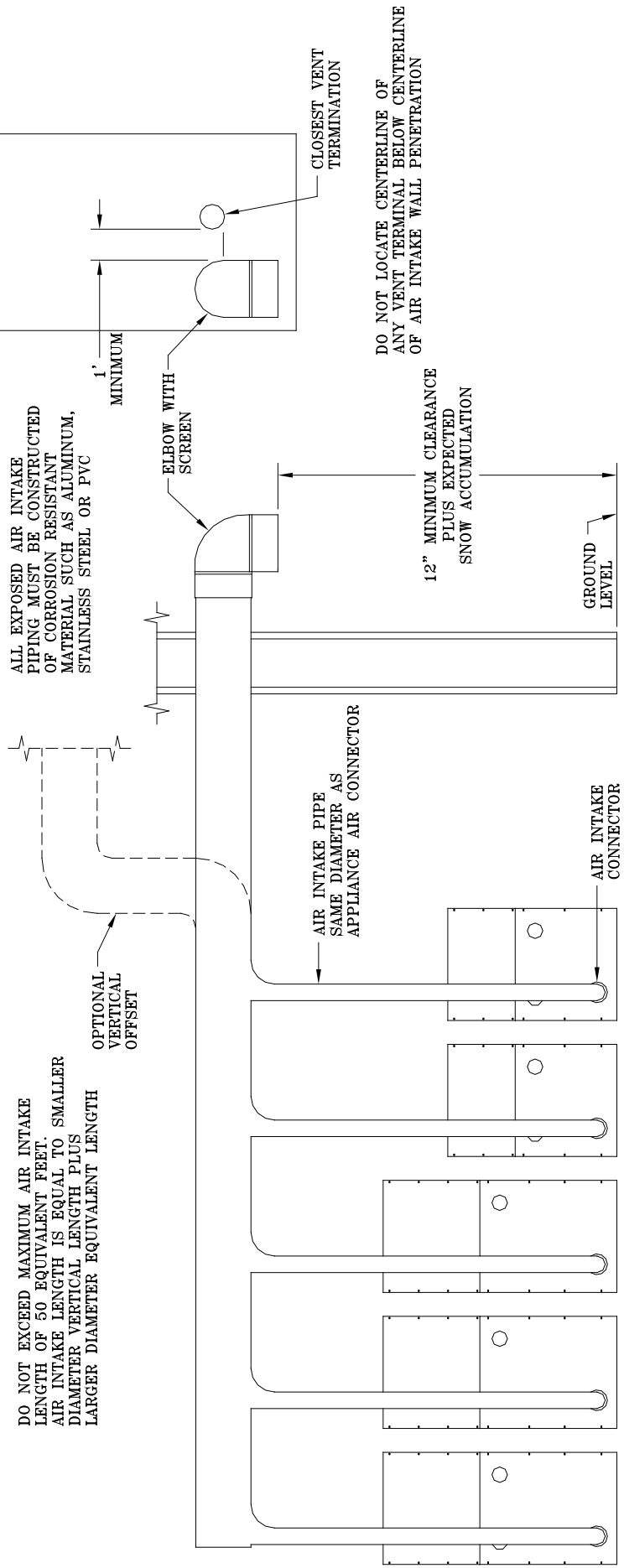

Figure 10: Modular System Horizontal Air Intake Piping

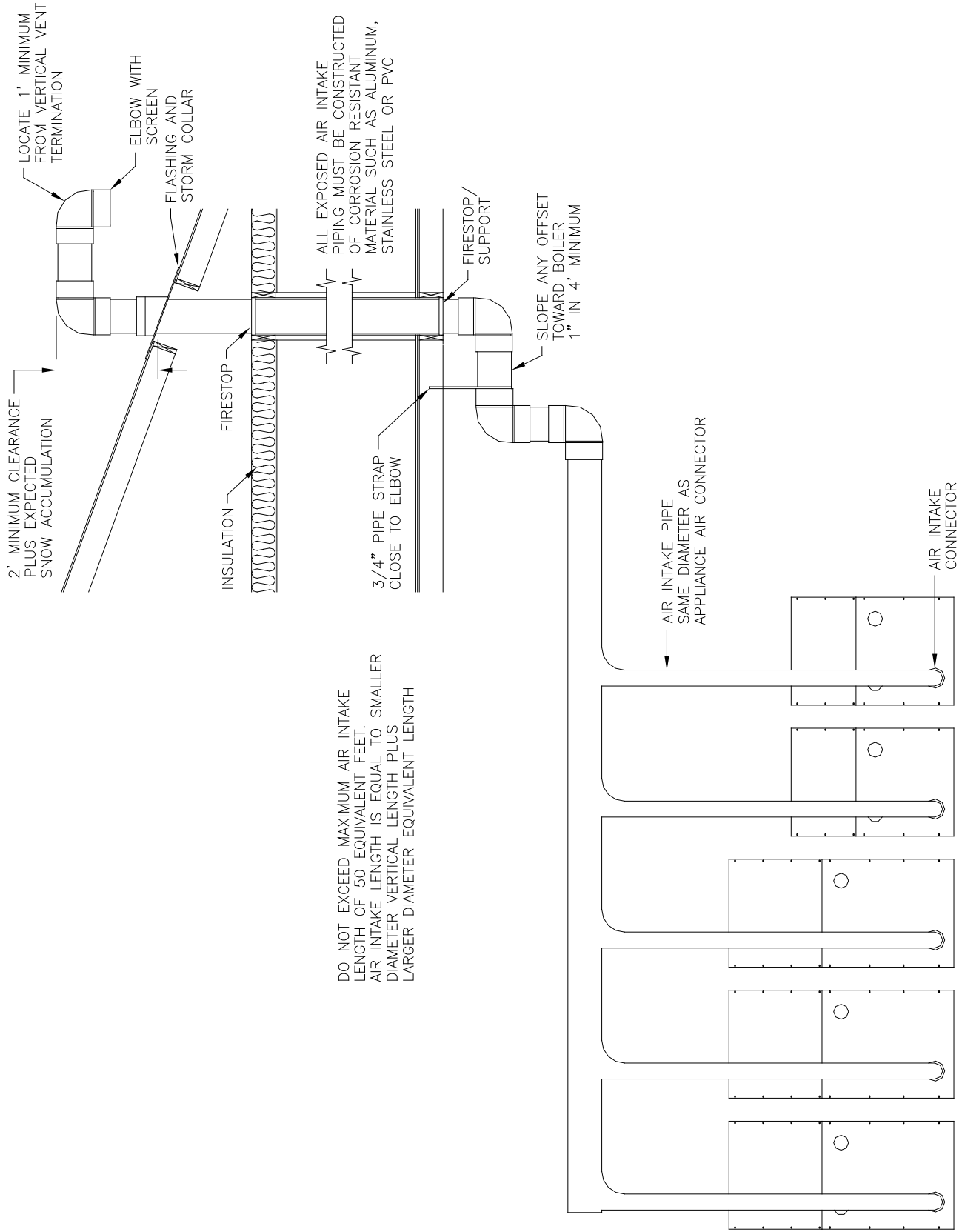
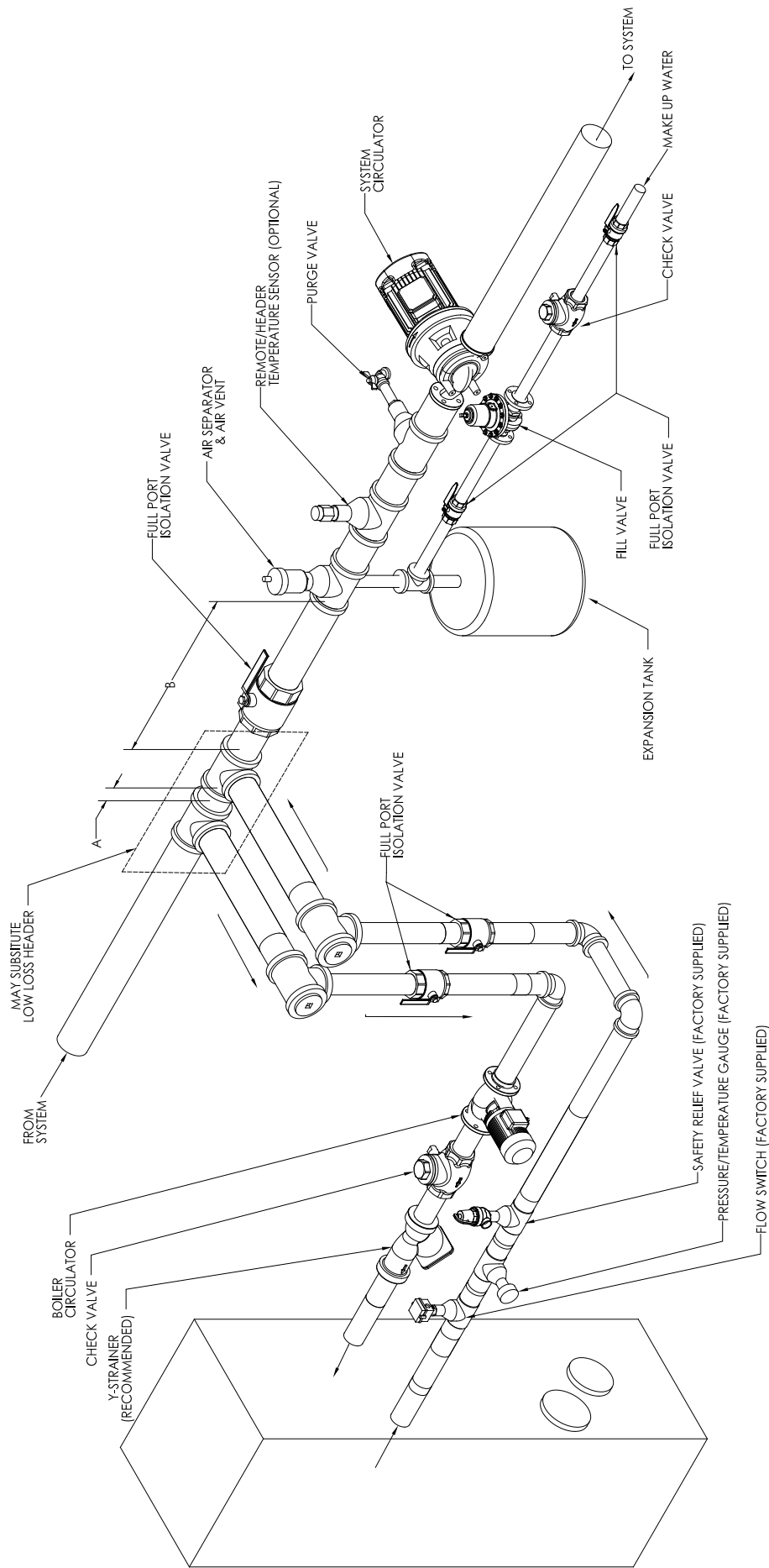

Figure 11: Modular System Vertical Air Intake Piping



- A. NO FURTHER APART THAN 12 INCHES OR FOUR PIPE DIAMETERS, WHICHEVER IS SMALLER
- B. AT LEAST 18" OF STRAIGHT PIPE FOR CONVENTIONAL AIR SCOOP.

NOTES:
 1. This is a suggested piping configuration. It is the installer's responsibility to confirm with local codes and ordinances for additional requirements.
 2. Pressure relief valve setting shall not exceed pressure rating of any component in the system.
 3. Boiler Pump must be sized to overcome pressure drop across entire boiler loop.

Figure 12: Near Boiler Water Piping (Single Boiler)

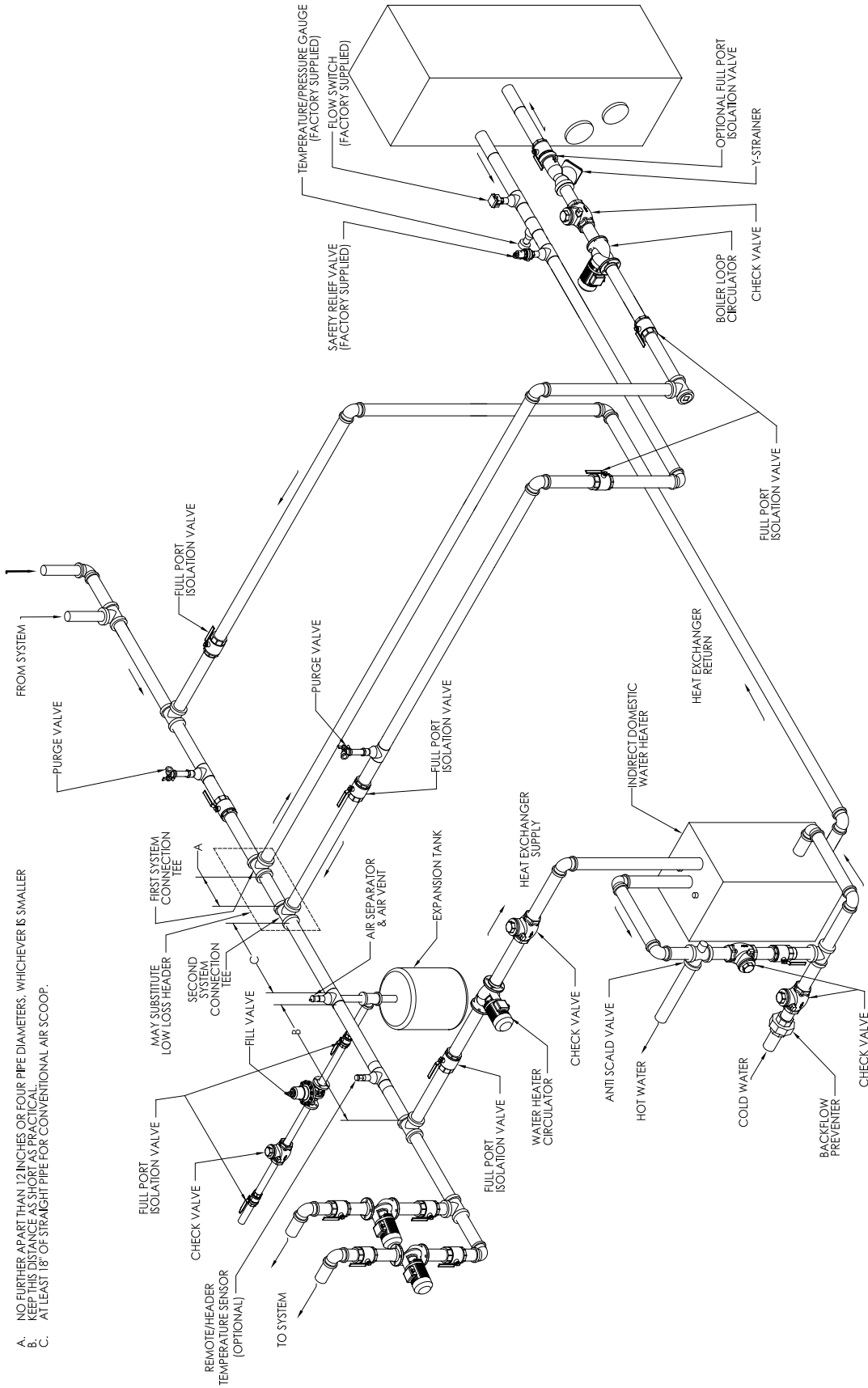

- A. NO FURTHER APART THAN 12 INCHES OR FOUR PIPE DIAMETERS, WHICHEVER IS SMALLER
- B. KEEP 18 INCHES AS SHOWN TO CLEAR CONVENTIONAL AIR SCOOP.
- C. AT LEAST 18" OF STRAIGHT PIPE FOR CONVENTIONAL AIR SCOOP.

NOTES:
 1. This is a suggested piping configuration. It is the installer's responsibility to confirm with local codes and ordinances for additional requirements.
 2. Pressure relief valve setting shall not exceed pressure rating of any component in the system.
 3. Boiler pump must be sized to overcome pressure drop across entire boiler loop.

Figure 13: Near Boiler Water Piping with Domestic Hot Water

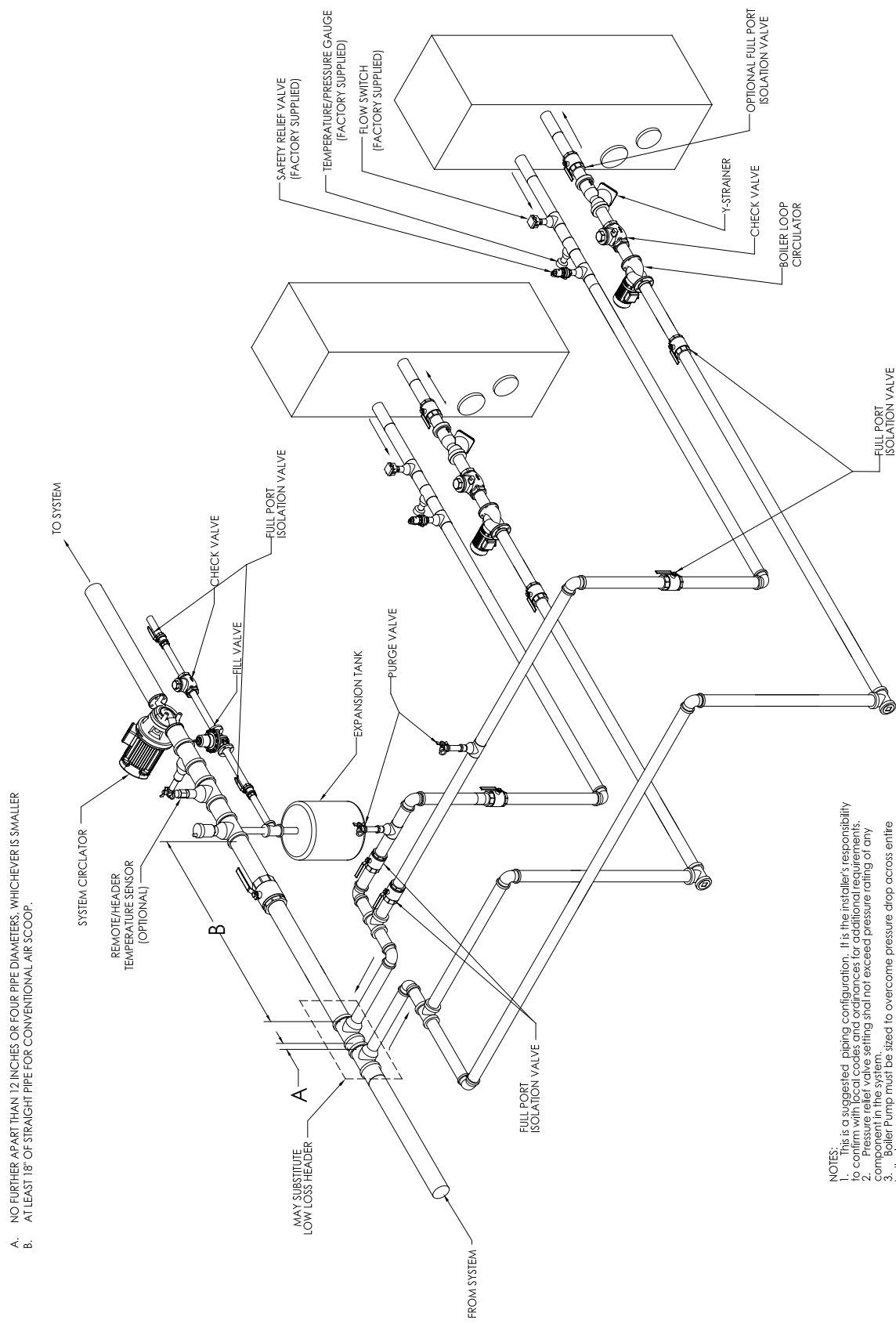

- A. NO FURTHER APART THAN 12 INCHES OR FOUR PIPE DIAMETERS, WHICHEVER IS SMALLER
- B. AT LEAST 18" OF STRAIGHT PIPE FOR CONVENTIONAL AIR SCOOP.

NOTES:
 1. This is a suggested piping configuration. It is the installer's responsibility to confirm with the manufacturer's instructions for additional requirements.
 2. Pressure relief valve setting shall not exceed pressure rating of any component in the system.
 3. Boiler Pump must be sized to overcome pressure drop across entire boiler loop.

Figure 14: Near Boiler Water Piping (Multiple Boilers)

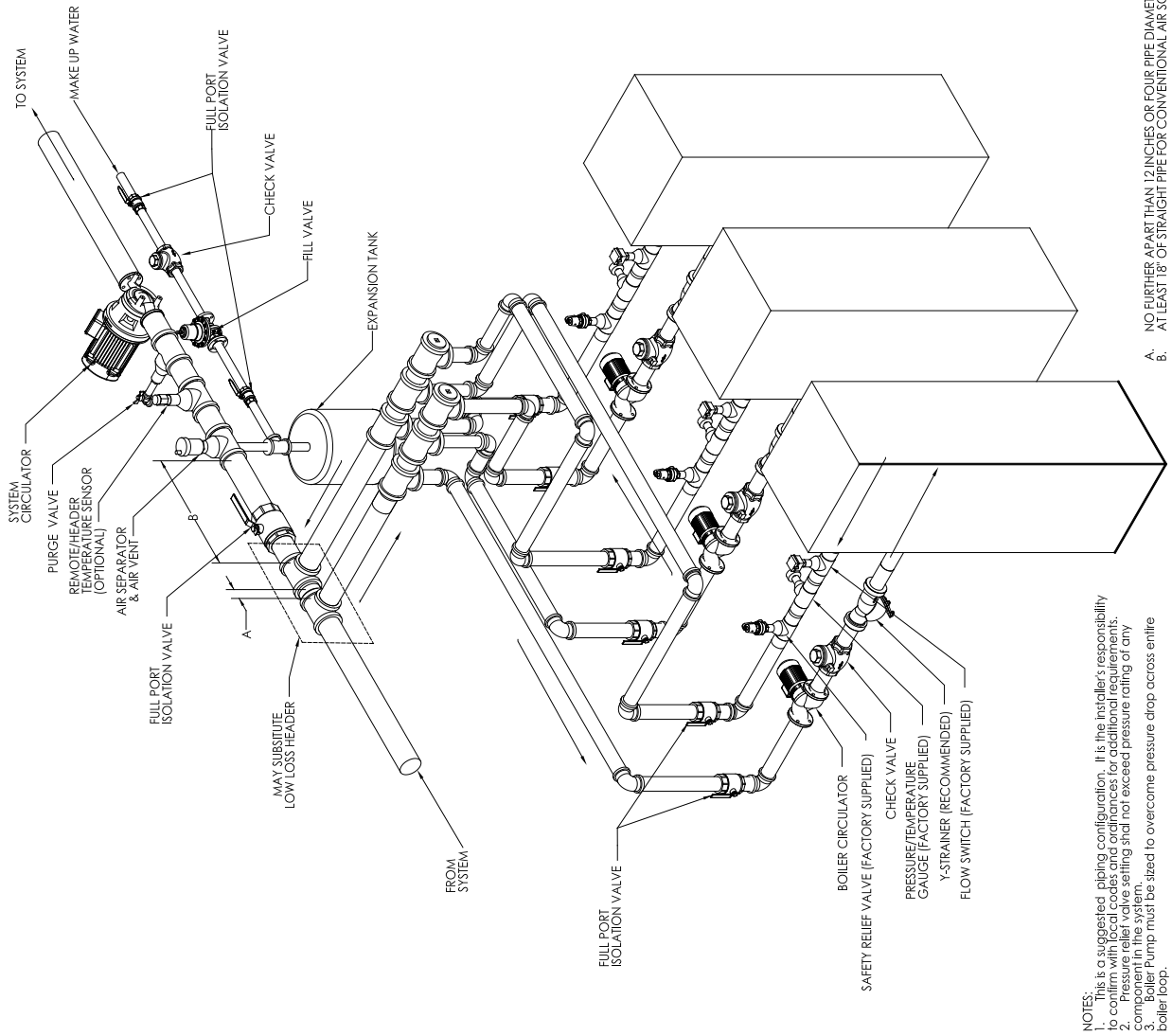

- A. NO FURTHER APART THAN 12 INCHES OR FOUR PIPE DIAMETERS, WHICHEVER IS SMALLER.
- B. AT LEAST 18" OF STRAIGHT PIPE FOR CONVENTIONAL AIR SCOOP.

NOTES:
 1. This is a suggested piping configuration. It is the installer's responsibility to confirm with local codes and ordinances for additional requirements.
 2. Pressure relief valve setting shall not exceed pressure rating of any component in the system.
 3. Boiler Pump must be sized to overcome pressure drop across entire boiler loop.

Figure 15: Modular System: Multiple Boiler Water Piping with Common Header

7. Electrical

- a. Each boiler must be provided with a dedicated fused disconnect.
- b. Install wiring and ground boiler in accordance with requirements of authority having jurisdiction. In absence of such requirements, reference the National Electrical Code, ANSI/NFPA 70 and/or CSA C22.1 Electrical Code.
- c. Refer to Figure 1 for electrical data for each size boiler.
- d. Refer to the Electrical Section for further warnings, cautions, notices and instructions.

NOTICE

Do not install boiler and circulator pump on the same fused disconnect.

8. Condensate Piping

- a. Each boiler requires separate condensate drains. In addition, most venting configurations require separate condensate drains in the vent system.

H. CONDENSATE DRAINS

- 1. Each boiler has two condensate drains - one from the primary heat exchanger, and one from the secondary heat exchanger. In addition, most vent configurations require a drain tee located in the vent piping. Pipe each condensate drain separately to a floor drain or condensate pump/sump. See Table 7 for maximum condensate flow rates.
- 2. Use continuous Teflon, high temperature resistant silicone tubing, or other tubing material compatible with flue gas condensate for condensate piping.

Boiler Model	Maximum Condensate Flow (gal/hr)
EVCA-750	3.4
EVCA-1000	4.5
EVCA-1500	6.8
EVCA-2000	9.1
EVCA-3000	18.6

CAUTION

Failure to properly pipe condensate system will greatly reduce boiler life. Do not install plugs, caps or valves on condensate piping.

Do not manifold boiler condensate drains or vent drains together.

Do not crimp condensate lines or reduce drain line inner diameter size.

Each condensate drain must contain a siphon/pigtail or trap to prevent flue gas flow through the condensate piping. The height of the top of the siphon/pigtail loop or trap shall not exceed the height of the condensate drain outlet.

- 3. A common condensate pump/sump may be used. Run separate piping from each condensate drain to the sump. A common drain may be used to discharge condensate from the sump. Consult pump/sump manufacturer for compatibility of pump/sump materials of construction. If a common sump is used, individual drain lines should be connected such that one drain cannot back feed into another drain.
- 4. Consult local authorities regarding disposal of flue gas condensate into public waste water system. Some jurisdictions require that the condensate be buffered before discharge. This buffering is commonly achieved by draining the condensate through a limestone bed. The condensate will be slightly acidic and range between 3 - 5 on the pH scale. Consult Thermal Solutions or a chemical treatment company for buffering systems.

CAUTION

Do not use material that is not approved for use with flue gas condensate for condensate piping.

IV. System Start-up

CAUTION

Failure to properly pipe boiler may result in improper operation and damage to boiler or structure.

Oxygen contamination of boiler water will cause corrosion of iron and steel boiler components, and can lead to boiler failure. Thermal Solutions Standard Warranty does not cover problems caused by oxygen contamination of boiler water.

Proper water treatment is required to avoid scale build-up on the inside of the boiler. Thermal Solutions standard warranty does not cover problems caused by scale build-up.

All piping either new or existing must be cleaned with a tri sodium phosphate (TSP) solution to remove mill scale and oils from the system. Failure to do so could result in premature failure of the heat exchanger (not covered by Thermal Solutions warranty).

On an existing or retrofit system, a filter or strainer must be installed on the system return prior to the boilers.

When using Glycol products, all Glycol manufacturers' requirements, including rust inhibitors, must be adhered. Max 50% Glycol.

A. System Check

1. Verify that the venting, water piping, gas piping and electrical system are installed properly. Refer to installation instructions contained in this manual.

WARNING

Completely read, understand and follow all instructions in this manual, Honeywell flame safeguard, and all other component manuals supplied with this boiler before attempting start up.

2. Confirm all electrical, water and gas supplies are turned off at the source and that chimney/vent is clear of obstructions. If boiler is controlled by an external control system, this system must be temporarily disconnected. The local boiler controls should be allowed to operate the boiler.
3. Remove the upper front jacket panel.
4. Confirm that all manual shut-off gas valves between the boiler and gas supply are closed.

WARNING

Prior to pressurizing the boiler water supply system, be sure the boiler piping air vent is properly installed. Refer to water piping section of this manual.

CAUTION

This boiler contains a manual gas shut-off valve inside of the upper front jacket panel

- B. Pressurize the Hydronic System - fill entire heating system with water and vent air from system. Use the following procedure on a Series Loop or multi-zoned system installed to remove air from the system while filling.
 1. Close full port ball valve in boiler supply piping.
 2. Isolate all zones by closing zone valves or shut-off valves in supply and return of each zone(s).
 3. Attach a hose to the hose bib in system piping and terminate hose in a five gallon bucket at a suitable floor drain or outside area.
 4. Starting with one circuit at a time, open zone valve or shut-off valve in system supply and return piping.
 - a. Open hose bib.
 - b. Open fill valve (Make-up water line should be located directly after full port ball valve in system supply piping between air scoop and expansion tank).
 - c. Allow water to overflow from bucket until discharge from hose is bubble free for 30 seconds.
 - d. Close the opened zone valve or shut-off valve for the zone being purged of air, then open the zone valve or shut-off valve for the next zone to be purged. Repeat this step until all zones have been purged. At completion, open all zone valves or shut-off valves.
 5. Close hose bib, continue filling the system until the pressure gauge indicates required system operating pressure. Close fill valve.

(Note - if make-up water line is equipped with pressure reducing valve, system will automatically fill to set pressure. Follow fill valve manufacturer's instructions).
 6. Open isolation valve in boiler supply piping.
 7. Remove hose from hose bib.
 8. Confirm that the boiler and system have no water leaks.

CAUTION

For the EVCA-3000, do not open or adjust mixing valve actuator rotating knob at the top of the actuator. This will affect proper boiler operation.

WARNING

The maximum operating pressure of this boiler is 160 psig. Never exceed this pressure. This boiler was supplied with a safety relief valve with a pressure relief setting specified at the time of purchase. The relief valve setting must be above the maximum operating pressure of the system. Consult Thermal Solutions if the desired system operating pressure is above the safety relief valve pressure setting. Do not plug or change safety relief valve.

C. Power the boiler - Turn on electrical supply to the boiler and circulation system at fused disconnect switches. Note that there is electrical power at certain components even with the power switch off. See wiring diagrams in Figures 9a-9f.

D. Power the Circulators - Turn system circulators on and purge air from the boiler and system piping.

1. Confirm motor rotation on boiler and system circulators.
2. Confirm that water flow switch is operating properly.

E. Pressurize the Fuel System - Turn on gas supply to the boiler gas piping.

1. Confirm that the supply pressure to the gas regulator supplied with the boiler conforms to Table 2 for maximum and minimum supply pressures.
2. Open the manual gas shut-off valves located upstream of the gas regulator supplied with the boiler. Do not open manual gas valve inside of boiler jacket.

DANGER

Do not use matches, candles, open flames or other ignition source to check for leaks.

3. Using soap solution, or similar non-combustible solution, electronic leak detector or other approved method, check that boiler gas piping valves, regulators and all other components are leak free. Eliminate any leaks.
4. Purge gas line of air.
5. Reset low gas pressure safety switch.

F. Select Operational Mode - Refer to the Thermal Solutions Boiler Control™ (TSBC™) Instruction Manual to select the desired control features.

G. Check Blower Rotation - Remove air filter to expose the fan blades.

1. Allow boiler to enter the sequence of operation.
2. While in Pre-Purge, position the flame control to the

test position.

3. Confirm proper blower motor rotation.
4. Shut boiler off and position the flame control back to run. Reinstall air filter.

H. Flame Safeguard Operation Check - Turn boiler operating switch to the ON position.

1. Allow boiler to complete prepurge and trial for ignition period. Once pilot flame is recognized by controller, position flame control switch to TEST position.
2. Look through the boiler sight glass and confirm that pilot flame is blue and steady and that the flame signal is steady and between 1.5 and 5.0 volts DC. On some boiler sizes, the pilot flame may not be visible. In these cases, confirm proper flame signal (as indicated above.)
3. Adjust pilot gas regulator until proper pilot manifold gas pressure is achieved per firetest report label. Pilot flame should be blue with very little yellow.
4. Turn the boiler off, place flame control switch in "run" position, and repeat Steps H.1 and H.2 at least five times until reliable pilot ignition and signal is achieved and confirmed.
5. With the pilot operating properly, allow boiler to continue to trial for main flame. Confirm that the flame control locks out on main flame failure.
6. Open the manual main gas shut-off valve located inside the boiler jacket. Using the procedure detailed in Step E.3, leak test gas piping and valves inside of jacket. Eliminate any leaks.
7. Reset flame safeguard and allow boiler to run through prepurge, trial for pilot and trial for main flame.
8. Confirm that main flame ignites smoothly.
9. Observe main flame and confirm that burner element is evenly orange without flickering.
10. Observe flame signal and confirm signal is steady and between 1.5 and 5.0 volts DC.
11. Using the procedure detailed in step E.3, leak test gas piping and valves inside of jacket. Eliminate any leaks.
12. Turn boiler off and repeat Steps H.7-H.10 at least five times to confirm proper main burner operation.

I. Begin Commissioning the boiler - With main flame on, at high fire, measure gas pressure upstream and downstream of the main gas valves

1. Adjust the manifold pressure to match the pressure indicated on the factory firetest label.
2. Reassure that the inlet gas pressure is within the acceptable range found in Table 2. Adjust if necessary.

WARNING

Failure to properly adjust gas input rate will result in over firing or under firing of the appliance. Improper and unsafe boiler operation may result.

3. Confirm that high and low gas pressure switches are functioning and are adjusted to prevent over firing or under firing of the boiler.
4. Adjust setting of air filter flow switch by rotating knob on switch counter clockwise until change filter light switch is illuminated. Turn switch knob clockwise ¼ turn past the point where the change filter light goes out. Replace upper front jacket panel.
5. With boiler running and all panels attached, measure oxygen (O₂) and carbon monoxide (CO) concentrations in the flue gas and flue gas temperature. Compare results with values given on factory firetest report supplied with the boiler.

DANGER

Failure to properly adjust excess air will result in unsafe levels of carbon monoxide. Variations in venting or combustion air pressure and temperature will change excess air. Adjust excess air levels so that variation in venting or combustion air pressures and temperatures caused by change of seasons, wind conditions, opening or closing of boiler room doors or windows do not cause the boiler to operate with carbon monoxide concentrations above 400 parts per million.

6. Verify that all safety and operating limits and flame controls are operating properly. These controls and limits include combustion air switch, water

temperature operating control, manual reset water temperature safety limit, vestibule fuseable link, mixer fuseable link, high and low gas pressure switches. Refer to manuals for these components for proper start-up and operating instructions. Follow all instructions contained in these manuals. This manual was provided with the boiler.

J. Finish Commissioning at the Boiler - Reconnect any wires from the external control system, if applicable.

1. Test function of external control system.
2. Place system control back in normal operation, if necessary.

K. Water Treatment - Contact reputable chemical treatment company for recommendations on proper water treatment for the installation. Each installation is different and must be analyzed based on local water conditions and boiler operating schedule.

The treatment chemicals must be compatible with copper, bronze, steel and cast iron materials of construction.

CAUTION

A proper water treatment and monitoring program will extend the life of the boiler. The water shall have a maximum water hardness of 8.5 grains or 150 ppm. The recommended pH range is 8.8 to 9.2. However, other aspects of water quality can affect boiler operation and longevity. A qualified water treatment expert should be consulted to develop a complete water treatment plan.

WARNING

Chemicals used in treating boiler water are toxic and/or harmful. Always use protective clothing and equipment when working with/near chemicals. Contact local authorities to determine if treated boiler water can be discharged into local waste water system.

V. Lighting Instructions

FOR YOUR SAFETY, READ BEFORE OPERATING



WARNING: If you do not follow these instructions exactly, a fire or explosion may result causing property damage, personal injury, or loss of life.

- A. This appliance is equipped with an ignition device which automatically lights the pilot. Do **NOT** try to light the pilot by hand.
 - B. BEFORE OPERATING smell all around the appliance area for gas. Be sure to smell next to the floor because some gas is heavier than air and will settle on the floor.
 - C. Do not use this appliance if any part has been under water. Immediately call a qualified service technician to inspect the appliance and to replace any part of the control system and any gas control which has been under water.
- If you cannot reach your gas supplier, call the fire department.

WHAT TO DO IF YOU SMELL GAS

- Do not try to light any appliance.
- Do not touch any electric switch; do not use any phone in your building.
- Immediately call your gas supplier from a neighbor's phone. Follow the gas supplier's instructions.

OPERATING INSTRUCTIONS

1. STOP! Read all the safety information (warnings, cautions etc.) in this manual.
2. Turn off all electric power to the appliance.
3. Set the system control so that there is **no** call for heat to the appliance.
4. This appliance is equipped with an ignition device which automatically lights the pilot and main burner. Do **not** try to light the pilot or main flame by hand.
5. Remove front door panel.
6. Locate the gas pilot valve at the rear of the appliance.
7. Locate the gas main valves at the rear of the appliance and at the end of the gas supply pipe inside the appliance.
8. Rotate gas shutoff valves clockwise  from "ON" position to "OFF". Make sure handle rests against stop.
9. Wait five (5) minutes to clear out any gas. Then smell for gas, including near the floor. If you smell gas, STOP! Follow "B" in the safety information above on this label. If you do not smell gas, go to the next step.
10. Rotate gas shutoff valves counterclockwise  from "OFF" to "ON". Make sure handle rests against stop. Do not force.
12. Turn on all electric power to the appliance.
13. Set thermostat to desired setting.
14. If the appliance will not operate, follow the instructions "TO TURN OFF GAS TO APPLIANCE" and call your service technician or gas supplier.
15. Move the switch to the "ON" position.
16. Set system control so that there is a call for heat from the system.
17. Observe prepurge, pilot ignition and main flame ignition.
18. If pilot or main flame ignition does not occur during initial attempt, remove the upper front jacket panel of the appliance. If the appliance pilot and main flame light, go to step 20.

OPERATING INSTRUCTIONS CONTINUED

19. Reset the burner control by pressing the reset button located on the burner control. If you do not know where the control reset button is, do not touch any part of the control system or wiring. Turn all gas and electrical power off to the appliance and call a qualified service technician.

20. Replace the upper front jacket panel.

21. Observe several on and off cycles of the water heater. If any light offs are excessively noisy or rough, or any questionable boiler operation is noticed, immediately turn off all gas and electrical power and call qualified service technician.

22. Should overheating occur or the gas supply fail to shut off, turn off the manual gas control to the appliance.

To Turn Off Gas To Boiler

1. Set the thermostat to lowest setting.

2. Turn off electric power to the appliance if service is to be performed.

3. Remove front door.

4. Rotate gas main shutoff valves, located inside the appliance, clockwise  from "ON" position to "OFF". Make sure handle rests against stop.

5. Replace front door.

6. At the rear of the unit, rotate the pilot and main gas valves clockwise  from "ON" position to "OFF". Make sure handle rests against stop.

VI. Boiler Operational Sequence

Boiler Sequence

BOILER STATE LCD Display		Terminal Number	Parameter/Note	Pre-Sequence States				Start/Stop Sequence States									
				Boiler Disable	Warm Weather Shutdown	Lockout	Standby	Pump Purge	Limit Hold	Purge / Pilot Ignition	Low Fire / Ignition	Main Ignition	Low Fire Hold	Boiler Running	Fan Post Purge	Pump Cooldown	
Parameter / Notes				a	b & c	a	a	3/d	-	-	-	-	53	-	54/d	4/d	
Interlock Inputs	Boiler Disable or Remote On/Off	RO	-	Boiler Enable/Disable On													
	Outdoor Air Temp > Warm Weather Shutdown Setpoint	O+,O-	44,30,75														
	Domestic Hot Water Priority	DP	20,74	Domestic Hot Water Demand Monitored													
	Low Fire Hold	SI	9														
	Fuel Valve Energized	CS	-														
	Flame Safeguard Alarm	AL	-														
	System Pump Feedback	SI	9	System Pump Feedback Monitored													
Limits Inputs	Call For Heat	R+,R- OR B,Q,B,C	70,71,72	Call For Heat													
	Recycling Limits (LC, OO, WF, GP and HL inputs)	LC, OO, WF, GP, HL	8,27,28	Recycling Limits Made													
	Non-Recycling Limits (Combustion Air Flow/CA Input)	CA	-	Non-Recycling Limits Made													
Relay Outputs	Call For Heat Relay	CH	-	Call For Heat Relay On													
	Lockout Indicator (Manual Reset Required)	LO	-														
	Spare Output	VI	-	Spare Output On													
	Boiler Pump	BP	2,30	Boiler Pump On													
	System Pump	SP	25,30	System Pump On													
	System Pump Backup Pump	SO	10	Starts in response to System Pump Feedback Input SI													
	Combustion Air Damper	SO	10,27/e	Combustion Air Damper Open													
Modulation Outputs	System Alarm	SO	10	Alarm Status is Monitored													
	Mixing Valve Output	MS,MR	6,79,80	Modulate													
	Firing Rate	Blower High Speed	V+,V-,P+,P-	49													
		Purge %	V+,V-,P+,P-	52													
		Modulation	V+,V-,P+,P-	-													
		Low Fire %	V+,V-,P+,P-	9,51/f													
	Blower 0 Volts	V+,V-,P+,P-	50														

Notes

- Boiler Pump is "On" when the Boiler Pump is set to "On Always" or the boiler is lead boiler and Boiler Pump is set to "On Lead".
- Boiler Pump is "On" when the Boiler Pump is set to "On Always" and WWSD is set to "WWSD of System Pump" or "Off".
- System Pump is "On" when the System Pump is set to "yes" and WWSD is set to either "WWSD of Boiler" or "Off".
- Boiler pump is "On" during Prepurge and Post Purge when Boiler Pump is set to "Purge" or boiler is lead & Boiler Pump is set to "On Lead".
- Combustion Air Damper Spare Output is maintained "On" for 2 minutes after the Call For Heat is removed.
- Modulation rate is held at purge % when low fire input is not provided.

Boiler Sequence (Continued)

Pre-Sequence States

BOILER STATE LCD Display	CONTROL MODE LCD Display	Description
Boiler Disabled	Any Mode (Except for Remote Control)	Boiler is prevented from starting, Remote On/Off (Enable) (Terminal RO) Input is not energized.
Warm Weather Shutdown	Any Mode (Except for Manual Mode)	Boiler is prevented from starting, Warm Weather Shutdown (WWSD) is enabled and outside air temperature is above the WWSD Setpoint.
Lockout	Any Mode	Boiler is prevented from starting, Flame Safeguard lockout is present. A Flame Safeguard manual reset is required.
Standby	Outlet Sensor & Local SP Mode	Control monitors boiler outlet temperature, a Call For Heat is initiated when boiler outlet temperature is below the Operational Setpoint.
	Remote Sensor & Local SP Mode	Control monitors Remote System Temperature, a Call For Heat is initiated when Remote System Temperature is below the Operational Setpoint.
	Outlet Sensor & Remote SP Mode	Control monitors boiler outlet temperature, a Call For Heat is initiated when boiler outlet temperature is below the Remote Setpoint Input (Terminal C+,C- or Modbus Interface).
	Remote Sensor & Remote SP Mode	Control monitors Remote System Temperature, a Call For Heat is initiated when Remote System Temperature is below the Remote Setpoint Input (terminal C+,C- or Modbus Interface).
	Remote Control Mode	Control monitors Remote On/Off (Enable) input (Terminal RO or Modbus Interface), a Call For Heat is initiated when input is energized.
	Manual Operation Mode	A Call For Heat is initiated when Manual Mode Menu item Boiler On/Off is set to On.

Start/Stop Sequence States

BOILER STATE LCD Display	CONTROL MODE LCD Display	Description
Pump Purge	Any Mode (Except Manual Mode)	Once a Call For Heat is initiated and Boiler Pump Purge is selected, the pump output is energized until the Pump Prepurge Time is complete. If the Call For Heat condition still exists at the end of the Prepurge Time (the temperature of the water at the sensor may rise with boiler water flowing passed it) the pump will continue to operate and the Call For Heat Relay is energized.
Limit Hold	Any Mode	Power is applied to the safety limit string. If any limits does not pass power (is not energized), the alarm LED and LCD display shows the reason the start sequence is on Hold. Refer to Trouble shooting section for explanation of individual lockout and alarm messages.
Purge / Pilot Ignition	Any Mode	After the limit string passes power, the fan is started, the modulation output is set to Purge Rate. When the purge period is complete, the flame safeguard sequences on the ignition transformer and pilot.
Low Fire / Ignition	Any Mode	When the Spare Input Low Fire is selected, modulation output is set to the Low Fire Speed when the Spare Input is energized.
Main Ignition	Any Mode	The main gas valve input is energized and the modulation output is held constant for an ignition stabilization period.
Low Fire Hold	Any Mode	The modulation output is held at the Low Fire for the Low Fire Hold time.
Boiler Running	Any Mode	When this Low Fire Hold time is complete, the modulation output is released to modulate.
Fan Post Purge	Any Mode	When water temperature is above setpoint, there is a Flame Safeguard or Limit fault, the Call For Heat is ended and the modulating output is set to Purge Rate for the Post Purge Time.
Pump Cooldown	Any Mode	When Boiler Pump Purge is selected, the boiler pump remains "on" until the boiler outlet temperature is less than the Post Purge Delta (default is 5 F) above the Boiler Inlet Temperature.

VII. Service/Maintenance

GENERAL GUIDELINES

1. A thorough and complete boiler inspection and check must be conducted a minimum of one (1) time per year.
2. Follow any checks and/or inspections that may be required as specified in the component manufacturer's instruction manuals.
3. Repair or replace any defective components immediately.
4. The following service procedures are required for proper and safe boiler operation.

DANGER

This boiler uses flammable gas, high voltage electricity, moving parts, and very hot water under high pressure. Assure that all gas and electric power supplies are off and that the water temperature is cool before attempting any disassembly or service.

More than one gas shut-off valve and electrical disconnect switch are used on the boiler. Assure that all gas valves and electrical disconnect switches are off before attempting any disassembly or service.

Do not attempt any service work if gas is present in the air in the vicinity of the boiler.

Never modify, remove or tamper with any control device.

WARNING

This boiler must only be serviced and repaired by skilled and experienced service technicians.

If any controls are replaced, they must be replaced with identical models.

Read, understand and follow all the instructions and warnings contained in all the sections of this manual.

If any electrical wires are disconnected during service, clearly label the wires and ensure that the wires are reconnected properly.

Never jump out or bypass any safety or operating control or component of this boiler.

Read, understand and follow all the instructions and warnings contained in ALL of the component instruction manuals.

Assure that all safety and operating controls and components are operating properly before placing the boiler back in service.

The service instructions contained in this manual are in addition to the instructions provided by the manufacturer of the boiler components. Follow component manufacturer's instructions. Component manufacturer's instructions were provided with the boiler. Contact component manufacturer for replacement if instructions are missing. Do not install, start up, operate, maintain or service this boiler without reading and understanding all of the component instructions. Do not allow the boiler to operate with altered, disconnected or jumpered components. Only use replacement components identical to those originally supplied by Thermal Solutions.

CAUTION

USE caution when servicing components behind upper front jacket panel. Filter/mounting bracket may cause head injury.

Label all wires prior to disconnection when servicing controls. Wiring errors can cause improper and dangerous operation.

Verify proper operation after servicing.

A. SAFETY AND OPERATING CONTROLS. OPERATION AND SHUT DOWN

Component	Function
Circuit Board Fuse	If the power draw of the control circuit exceeds approximately 5 amps, the circuit board fuse trips and prevents the boiler from operating until the fuse is replaced.
Power Switch	If this switch is in the off position, power is interrupted to the control circuit of the boiler, which prevents the boiler from operating. If the switch is in the on position, power is supplied to the control circuit.
Operating Aquastat	If the boiler water temperature exceeds the adjustable set point, power is interrupted to the control circuit of the boiler, which prevents the boiler from operating. When the boiler water temperature drops below the set point minus the adjustable differential setting, power is again supplied to the control circuit.
Manual Reset High Limit Aquastat	If the boiler water temperature exceeds the adjustable set point, power is interrupted to the control circuit of the boiler, which prevents the boiler from operating. Power is interrupted until the control is manually reset by pressing the control's reset button. When the button is depressed, power will again be supplied to the control circuit.
Flow Switch	If the water flow through the boiler drops below the fixed flow rate required to move the control's paddle enough to close the controls contacts, power is interrupted to the control circuit, which prevents the boiler from operating. When the water flow rate is increased, the paddle closes the control's contacts and power is supplied to the control circuit.
Pressure (Safety) Relief Valve	If the pressure inside the appliance exceeds the fixed set point, the valve opens mechanically and discharges water. The valve remains open until the pressure inside the appliance drops below the set point.
Mixer Fuseable Link	If the temperature in the interior of the burner exceeds the fixed set point, The contacts of the switch open and power is interrupted to the control circuit, which prevents the boiler from operating. Power is interrupted until the switch is replaced.
Vestibule Fuseable Link	If the temperature in the interior of the vestibule enclosure exceeds the fixed set point, the contacts of the switch open and power is interrupted to the control circuit, which prevents the boiler from operating. Power is interrupted until the switch is replaced.
High and Low Gas Pressure Switches	If the gas pressure reaches a point below the adjustable set point, or above the adjustable set point, the contacts of the switch open and power is interrupted to the control circuit, which prevents the boiler from operating. Power is interrupted until gas pressure is between the high and low set points and the control is manually reset by moving the switch to the reset position. The switches will not reset until the gas pressure is within the set point parameters.
Combustion Air Flow Switch	If the differential air pressure drops below the fixed set point, the contacts of the switch open and power is interrupted to the control circuit, which prevents the boiler from operating. Power is interrupted until air flow increases so that the contacts close.
Flame Safeguard Control	Refer to the manual supplied with the boiler.
Variable Frequency Drive (VFD)	The variable frequency drive's primary function is to vary the rotational speed of the blower fan based on the air requirements of the boiler combustion process. The VFD responds to a 0-10 VDC signal from the TSBC.
Thermal Solutions Boiler Control™ (TSBC)™	The Thermal Solutions Boiler Control™ (TSBC™) is a complete boiler and automation system. It provides advanced boiler modulation control, operating control, diagnostics, multiple boiler lead lag and auxiliary device control. Refer to the TSBC manual shipped with the boiler to learn more about these features and functions.

B. TROUBLESHOOTING GUIDE

Alarm Messages

Alarm Messages are shown one at a time in priority order. The message closest to the top of this list is displayed first. Following messages are not shown until the higher priority message has cleared. All alarm messages are also stored in the Fault History.

LCD Display Alarm Message	Recommended Action	Explanation
Low Water Level	Manually Reset the Low Water Cutoff	Low Water Cutoff Switch When this option is configured and an instrument is installed, the manual reset low water safety relay is preventing the boiler from starting. If terminal (LC) does not receive power and the Call For Heat output (CH) is powered, the "Low Water Level" Message is displayed.
Off Switch	Turn Burner Switch On	Burner Switch is Off Control switch is in the OFF position and is preventing the boiler from starting. If terminal (OO) does not receive power and the Call For Heat output (CH) is powered the "OFF Switch" Message is displayed.
Low Water Flow	Ensure Boiler Pump is Running and Boiler Water Flow is Unobstructed	Low Water Flow Switch Low water flow is preventing the boiler from starting. If terminal (WF) does not receive power and the Call For Heat output (CH) is powered, the "Low Water Flow" Message is displayed.
Fuel Limit	Manually Reset the Fuel Pressure Switch	Low or High Gas Pressure Switch The low or high gas pressure switch is preventing the boiler from starting. If terminal (GP) does not receive power and the Call For Heat output (CH) is powered, the "Fuel Limit" Message is displayed.
High Temp Limit	Manually Reset the High Temperature Aquastat	High Limit Temperature The high temperature limit (HL) (and operational temperature limit when provided) aquastat is preventing a boiler start. If terminal (HL) does not receive power and the Call For Heat output (CH) is powered, the "High Temp Limit" Message is displayed.
Low Air Flow	Check Combustion Air Blower and Air Pressure Switch Settings and Wiring	Low Air Flow or Blocked Vent Switch Not Made The air flow (and blocked vent switch when installed) is preventing a boiler start. If terminal (CA) does not receive power and the Call For Heat output (CH) is powered, the "Low Air Flow" Message is displayed.
FSG Fault	Manually Reset Required, Refer to Flame Safeguard Manual Corrective Actions	Flame Safeguard Fault The Flame Safeguard is preventing a boiler start. If terminal (AL) receives power at any time, the "Flame Failure" Message is displayed.
Outlet Temp Fail	Check Wiring and Sensor	Boiler Outlet Temperature Sensor Fail The boiler outlet temperature sensor is not connected or is reading above or below a valid range. When the boiler outlet sensor fails and the Outlet Sensor mode was selected, the control will transfer to Lost Sensor Blind Mode.
Inlet Temp Fail	Check Wiring and Sensor	Boiler Inlet Temperature Sensor Fail The boiler inlet temperature sensor is not connected or is reading above or below a valid range. When the boiler inlet sensor fails, the mixing valve output will drive to 0% and low temperature alarm and maximum water differential (boiler outlet minus boiler inlet) temperature hold are disabled.
OA Temp Fail	Check Wiring and Sensor	Outside Air Temperature Sensor Fail The outside air sensor is configured and is not connected or is reading above or below a valid range. When the outside air sensor fails, the warm weather shutdown (WWSD) and outside air reset control logics are disabled.
Remote Temp Fail	Check Wiring and Sensor	Remote System Temperature Sensor Fail The remote system temperature sensor is configured and is not connected or is reading above or below a valid range. If Remote System Temperature Sensor mode was selected, the control will transfer to Boiler Outlet Sensor Mode.

TROUBLESHOOTING GUIDE (CONTINUED)

LCD Display Alarm Message	Recommended Action	Explanation										
Remote Input Fail	Check Wiring and Remote System	<p>Remote Control Input Fail The Remote Control Input is configured and is not connected or is above or below a valid range. When the remote control input fails, the following control mode changes are taken automatically:</p> <table border="1" data-bbox="649 399 1518 541"> <thead> <tr> <th data-bbox="649 399 1104 426">Selected Modes</th> <th data-bbox="1104 399 1518 426">Resulting Control Mode</th> </tr> </thead> <tbody> <tr> <td data-bbox="649 426 1104 453">Remote Mod</td> <td data-bbox="1104 426 1518 453">Outlet Sensor and Local Setpoint</td> </tr> <tr> <td data-bbox="649 453 1104 480">Remote Mod & Remote Sensor</td> <td data-bbox="1104 453 1518 480">Remote Sensor and Local Setpoint</td> </tr> <tr> <td data-bbox="649 480 1104 508">Remote SP</td> <td data-bbox="1104 480 1518 508">Outlet Sensor and Local Setpoint</td> </tr> <tr> <td data-bbox="649 508 1104 535">Remote SP & Remote Sensor</td> <td data-bbox="1104 508 1518 535">Remote Sensor and Local Setpoint</td> </tr> </tbody> </table>	Selected Modes	Resulting Control Mode	Remote Mod	Outlet Sensor and Local Setpoint	Remote Mod & Remote Sensor	Remote Sensor and Local Setpoint	Remote SP	Outlet Sensor and Local Setpoint	Remote SP & Remote Sensor	Remote Sensor and Local Setpoint
Selected Modes	Resulting Control Mode											
Remote Mod	Outlet Sensor and Local Setpoint											
Remote Mod & Remote Sensor	Remote Sensor and Local Setpoint											
Remote SP	Outlet Sensor and Local Setpoint											
Remote SP & Remote Sensor	Remote Sensor and Local Setpoint											
Comm Failure	<p>Confirm each boiler has a unique address</p> <p>Check Wiring and Remote System</p>	<p>Communication Failure The Modbus or Peer-To-Peer network has failed. When the Modbus network fails the following control mode changes are taken automatically:</p> <table border="1" data-bbox="649 667 1518 810"> <thead> <tr> <th data-bbox="649 667 1104 695">Selected Modes</th> <th data-bbox="1104 667 1518 695">Resulting Control Mode</th> </tr> </thead> <tbody> <tr> <td data-bbox="649 695 1104 722">Modbus Mod</td> <td data-bbox="1104 695 1518 722">Outlet Sensor and Local Setpoint</td> </tr> <tr> <td data-bbox="649 722 1104 749">Modbus Mod & Remote Sensor</td> <td data-bbox="1104 722 1518 749">Remote Sensor and Local Setpoint</td> </tr> <tr> <td data-bbox="649 749 1104 777">Modbus SP</td> <td data-bbox="1104 749 1518 777">Outlet Sensor and Local Setpoint</td> </tr> <tr> <td data-bbox="649 777 1104 804">Modbus SP & Remote Sensor</td> <td data-bbox="1104 777 1518 804">Remote Sensor and Local Setpoint</td> </tr> </tbody> </table> <p>After a Modbus communication failure, the 'Comm Failure' alarm is not cleared until communication is restored and successfully writes to both the Remote On / Off Modbus Command (00004) and Remote Firing Rate or Remote Setpoint (40006) points have been completed, power is cycled or the protocol parameter is changed to Peer-To-Peer and then back to Modbus.</p> <p>When a Peer-To-Peer network has failed the boilers begin operation as stand alone boilers using the selected parameters.</p> <p>After a Peer-To-Peer communication failure the 'Comm Failure' alarm is not cleared until communication is restored and the boiler rejoins a network with at least one other boiler, power is cycled or the protocol parameter is changed to Modbus and then back to Peer-To-Peer.</p>	Selected Modes	Resulting Control Mode	Modbus Mod	Outlet Sensor and Local Setpoint	Modbus Mod & Remote Sensor	Remote Sensor and Local Setpoint	Modbus SP	Outlet Sensor and Local Setpoint	Modbus SP & Remote Sensor	Remote Sensor and Local Setpoint
Selected Modes	Resulting Control Mode											
Modbus Mod	Outlet Sensor and Local Setpoint											
Modbus Mod & Remote Sensor	Remote Sensor and Local Setpoint											
Modbus SP	Outlet Sensor and Local Setpoint											
Modbus SP & Remote Sensor	Remote Sensor and Local Setpoint											
Low Inlet Temp	<p>Check return water temperature. Consider system or operational changes to avoid low temperature events</p> <p>Check wiring and sensor</p>	<p>Low Boiler Inlet Temperature If the boiler inlet temperature is below the Low boiler inlet temperature setpoint, the "Low Inlet Temp" Message is displayed and the boiler inlet temperature history is stored.</p>										
Memory Failure	<p>Call Factory Reset all memories in System menu: Clr BIT History Clr Alarm Hist Clr Run Time Cnt Clr Cycle Cnt Factory Defaults</p> <p>(Factory Level Password is required)</p>	<p>Memory Failure New software has been installed in the Thermal Solutions Boiler Control (TSBC) or a power interruption has caused a memory failure. The Call For Heat will be prevented until the condition is cleared.</p>										

C. PERIODIC MAINTENANCE RECOMMENDED CHECK LIST

Frequency	Component/Item	Recommended Test
Daily Maintenance	Boiler surroundings	Inspect the area to assure proper clearance to combustible materials, gasoline, and other flammable vapors and liquids.
	Gauges, monitors, and indicators	Make visual inspection and record readings.
	Combustion Properties	Check combustion properties as specified in section VII, part D.
	Burner flame	Make visual inspection of burner flame as stated in section VII, part D.
	Low Draft, fan air pressure, and damper position interlocks	Test low draft, fan, air pressure, and damper position interlocks according to instructions if so equipped.
Weekly Maintenance	Igniter	Make visual inspection, check flame signal strength; log.
	Flame signal strength	Read and log flame signal meter, read for both pilot and main flames.
	Flame failure detection system	Close manual fuel supply for (1) pilot, (2) main fuel cock, and/or valve(s); check safety shutdown timing. Refer to section VII, Part D.
	Firing rate control	Check firing rate control, place TSBC™ in manual mode and check high and low firing settings for proper operation.
	Pilot and/or main fuel valves	Open limit switch and make aural and visual check; check valve position indicators and check fuel meters if so fitted.
	Low-water fuel cutoff	Test low-water fuel cutoff device and alarm according to manufacturer's instructions.
Monthly Maintenance	Flue, vent, stack, condensate drains, and outlet dampers	Confirm that components are gas tight and free from obstructions to flow.
	Gas pressure interlocks	Test high and low gas pressure interlocks.
	Water condition	Test condition of water, correct condition as needed.
Semi-Annual Maintenance	Gauges, monitors, and indicators	Recalibrate all indicating and recording gauges.
	Flame failure detection system	Check components.
	Condensate drain tubes	Check drain tubes have liquid in trap and condensate is properly directed.
	Air filter	Check air filter as specified in section VII, Part D.
	Interlocks and valves	Check piping and wiring of all interlocks and shut off valves if so equipped.
	Circulators and system pumps	Maintain according to manufacturers' instructions.
Annual Maintenance	Flue, vent, stack, or outlet dampers	Confirm that components are gas tight and free from obstructions to flow.
	Combustion Properties	Check combustion properties as specified in section IV, Part I, Step 5.
	Flame failure detection system	Conduct pilot turndown test according to manufacturer's instructions. This test is required annually and after any adjustments to flame scanner mount or pilot burner.
	Pilot and/or main fuel valves	Check all coils and diaphragms; test other operating parts of all safety shutoff and control valves.
	Pilot and/or main fuel valves	Perform leakage test on pilot and main gas and/or oil fuel valves, in accordance with instructions.
	Flame safeguard	Test purge timing according to manufacturer's instructions.
	Air Filter	Replace
	Boiler trim	Remove lower front jacket panel and check for any signs of corrosion and leaks.
	Secondary Heat Exchanger	Check and clean if dirty. Refer to section VII, Part D.
	High limit and operating temp. controls	Test proper operation.
Mixing Valve	Test proper operation. Refer to section VII, Part D.	
As-Required	Low-water fuel cutoff	Recondition or replace.
	Safety relief valves	Test safety relief valves in accordance with ASME Boiler and Pressure Vessel Code, Sections VI and VII.

D. INSPECTION AND CLEANING PROCEDURES

Daily Boiler Inspection & Check

1. Inspect the area to assure proper clearance from combustible materials, gasoline, and other flammable vapors and liquids.
2. Observe burner color. See "Pilot and Main Flame" instructions later in this section
3. Check flame control for proper operation and shutdown.
4. Check vent and air intake piping for any obstructions.
5. Check for any water leaks in the entire boiler assembly.
 - a.) For leaks in the boiler secondary Victaulic® piping:
 - i) Disassemble the leaking coupling
 - ii) Clean and lubricate the gasket. Clean all surfaces mating to the gaskets prior to reassembly.
 - iii) See www.victaulic.com for specific details about the QuickVic® style 107 couplings.

NOTICE

Victaulic® brand water-based Vic-Lube shall be used to lubricate all coupling and flange gaskets prior to reassembly. Oil-based lubricants shall not be used.

6. Check for any gas leaks.
7. Check condensate drains for any obstructions.
8. Clean any debris or trash from area.
9. Check the low draft, fan, air pressure, and damper position interlocks, according to the manufacturer's instructions, if so equipped.
10. Check gauges, monitors, and indicators to assure they are functioning properly.
11. Log that the above maintenance was completed in an appliance log. Maintain log near appliance location.

Weekly Boiler Inspection & Check

1. Check flame strength for both pilot and main flames; log.
2. Check ignitor.
3. Check operation of the flame failure detection system for both pilot and main flame.
4. Check firing rate control for proper operation.
5. Check pilot and main fuel valves:
Open limit switch and make aural and visual inspection, check valve position indicators and fuel meters, if provided.
6. Check the low water cutoff device and alarm according to the manufacturer's instructions.

Monthly Safety and Operating Control Checks

1. Check proper operation of all boiler system safety and operating controls including flame safeguard.
2. Check proper operation safety relief valve.
3. Check condition of water (pH, alkalinity, hardness).
Correct water condition as needed.
4. Check carbon monoxide level in flue products.
5. Check venting/air intake and condensate drain tubes for obstructions.
6. Repair or replace any inoperative or damaged components.
7. Low water cutoff, float type (if so equipped):
Monthly blowoff. During the heating season, if an external float type low water cutoff is above the boiler, the blowoff valve should be opened once per month (use greater frequency where conditions warrant), to flush out

the sediment chamber so the device will be free to function properly.

8. Inspect and replace air filter as needed.
9. Check high and low gas pressure switch interlocks.
10. Log service procedure in appliance log.

Semi-Annual "Tune-Up"

1. Inspect condensate drain tubes for deterioration, cracking, etc.
2. Inspect air intake and exhaust pipes for leaks, deterioration, scale, etc.
3. Measure fuel input, oxygen and carbon monoxide in flue products.
4. Adjust burner to obtain values noted in firetest report.
5. Complete safety and operating control checks.
6. Repair or replace any inoperative or damaged components.
7. Log service procedures in water appliance log.

Annual Boiler Inspection and Check

1. Replace air filter.
2. Remove and inspect pilot assembly.
3. Remove lower front jacket panel and check for any signs of corrosion and leaks.
4. Remove pipe plugs in header and inspect inside of copper tubes and header.
5. Flush boiler and mechanically remove any scale.
6. Remove, inspect, and clean water flow switch and low water cutoffs.
7. Complete "tune-up" procedures (See previous instructions).
8. Log service procedures in appliance log.
9. Repair or replace any inoperative or damaged components.
10. Vent/Air Intake System. Inspect for obstructions, soot accumulation, proper support, and deterioration of pipe, fittings, and joints.
 - a.) Clean terminal screens. Terminals must be free of obstruction, undamaged, with screens securely in place.
 - b.) Terminal and wall thimbles (if used) must be weathertight.
 - c.) Pipe must be full round shape, and show no damage from impact or excessive temperature.
 - d.) Pipe must be supported at minimum (5) foot intervals and must not sag.
 - e.) All vent joints must be secure and watertight.
 - f.) Horizontal vent tee drain or vertical vent tee drain (if used) must have minimum 6 inch trap and allow condensate to flow freely.
To clean:
 - i.) Disconnect drain tube from drain fitting
 - ii.) Flush drain tube with water. Fill trap with water.
 - iii.) Securely fasten drain tube to drain fitting, providing gas-tight and watertight seal.
 - g.) If pipe must be disassembled for removal of obstructions or resealing of joint, see VENTING section of the manual.
11. Low Water Cutoff (if so equipped)
 - a.) Float type low water cutoffs should be dismantled annually by qualified personnel, to the extent necessary to ensure freedom from obstructions and proper functioning of the working parts.
 - i.) Inspect connecting lines to boiler for accumulation of mud, scale, etc. and clean as required.

- ii.) Examine all visible wiring for brittle or worn insulation and make sure electrical contacts are clean and that they function properly. Give special attention to solder joints on bellows and float when this type of control is used.
 - iii.) Check float for evidence of collapse and check mercury bulb (where applicable) for mercury separation or discoloration.
- b.) Probe Type: Probe type LWCO should be removed once a year and cleaned of any dirt accumulations to assure proper operation. Do not attempt to repair mechanisms in the field. Complete replacement mechanisms, including necessary gaskets and installation instructions, are available from the manufacturer.
12. Verify proper operation after servicing.

Air Filter

- A. Perform a visual inspection of air filter and replace as necessary.
1. Remove upper front panel.
 2. Remove tube from nipple on filter assembly.
 3. Remove wing nut.
 4. Remove filter assembly from boiler. For the EVCA-3000: to facilitate assembly removal, loosen the two top screws on the lower front panel and lean the lower front panel forward. Remove the blower filter front plate, if necessary.
 5. Remove foam prefilter and wash with soap and water.
 6. Replace primary filter as necessary.

Pilot and Main Flame

- A. Perform a visual inspection of pilot burner flame.
1. Refer to the flame safeguard instruction manual and conduct a pilot turndown test.
 2. Observe pilot operation and record pilot signal. Flame should be steady medium hard blue.
- B. Pilot cleaning and maintenance
1. Shut off gas supply and disconnect electrical service.
 2. Disconnect scanner, ignition electrode, loosen and remove pilot gas line and combustion air line from fan.
 3. Remove mounting fasteners and pull pilot assembly from heat exchanger.
 4. Examine pilot electrode and set gaps to 1/8" if needed. Clean as required.
 5. Reassemble in reverse order using a new gasket available from Thermal Solutions.
- C. Perform a visual inspection of main burner flame
1. Observe main flame and record flame signal. Flame color should be steady deep orange in color

- with dark blue checkerboard pattern throughout.
2. Main burner requires no cleaning or annual maintenance.

Check Combustion and Safety Controls

- A. Check flame failure detection system with system operating.
1. Pilot
 - a.) Refer to the flame safeguard instruction manual.
 - b.) Manually close pilot fuel supply and verify lock out of primary control.
 2. Main Flame
 - a.) Refer to the flame safeguard instruction manual.
 - b.) Close manual main fuel shut-off valve and

CAUTION

Do not attempt to remove or service burner. Damage to the burner may result. Consult boiler manufacturer.

Secondary Heat Exchanger

- A. Remove vent pipe from stack adapter
- B. See Figure 18. Use flashlight to inspect the fins of the heat exchanger through stack adapter opening.
- C. If excessive deposits are found, refer to the following section for cleaning instructions.
- D. Re-install vent on stack adapter.

Cleaning Secondary Heat Exchanger for EVCA Units:

- A. Remove vent pipe from stack adapter.
- B. See Figure 18. Using the opening in the stack adapter (1) as a point of entry, remove foreign matter from the secondary heat exchanger (2) by spraying an industrial coil cleaner as specified by the manufacturer.
- C. Reinstall vent on stack adapter.

Mixing Valve:

- A. Set TSBC to control the mixing valve manually.
- B. Stroke the valve from 0-100%, periodically stopping to check for proper positioning and valve seizures.
- C. Troubleshoot control signals and valve actuator for positioning errors.
- D. Replace valve body if seizure occurs.
 1. When removing/servicing the mixing valve, never lift by the mixing valve actuator. Lift the valve body.

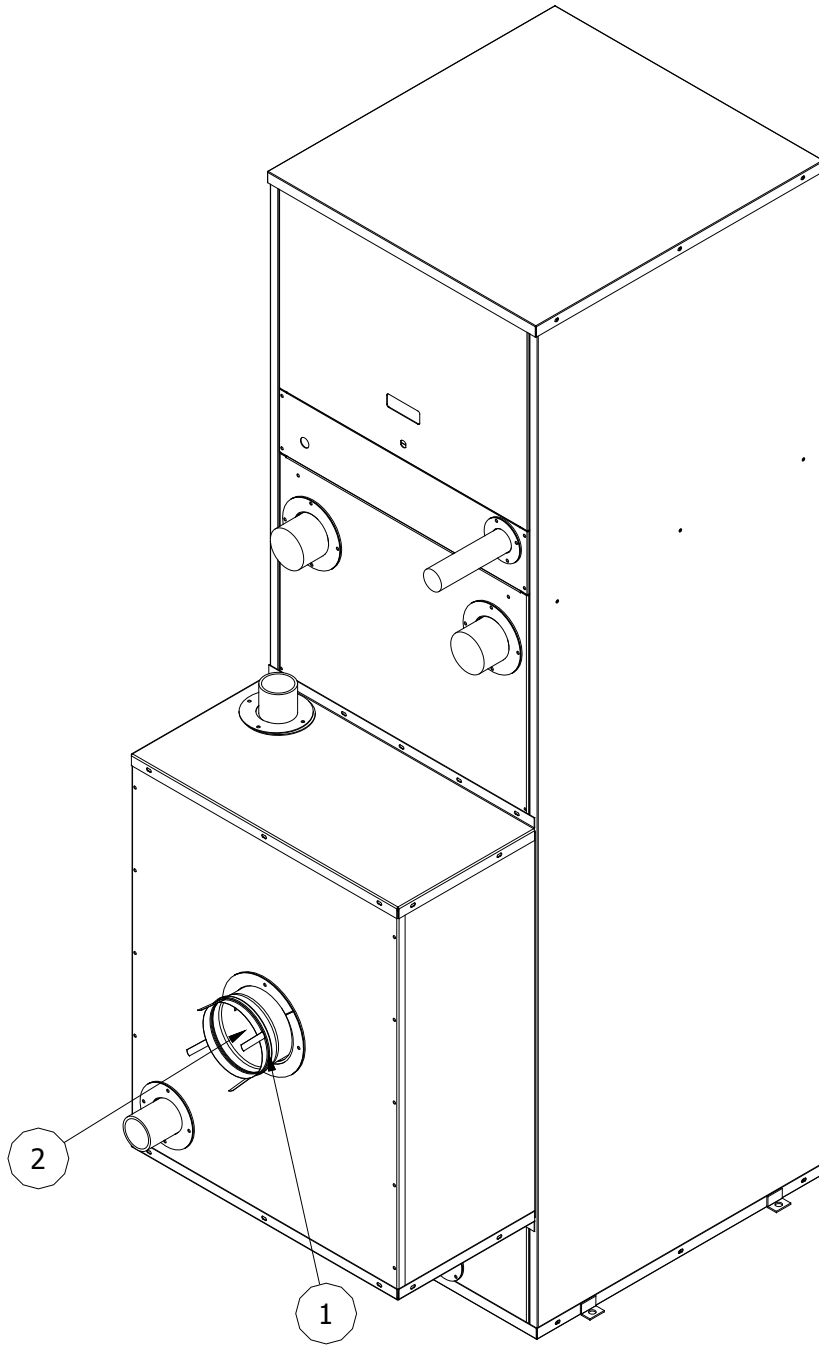

Figure 18: Cleaning Secondary Heat Exchanger

This page intentionally left blank

VIII. Repair Parts

EVCA Series repair parts can be ordered through your nearest Thermal Solutions Representative for delivery from Lancaster, PA.

The Representatives can also advise as to the availability of product and repair parts from local sources.

Contact Thermal Solutions for your Representative at:

Thermal Solutions Products LLC
1175 Manheim Pike
Lancaster, Pennsylvania 17601
Telephone (717) 239-7642
Fax (877) 501-5212 (toll free)
www.thermalsolutions.com

WARNING

The repair parts noted in this section are for a standard EVCA Series boiler. Different contents and components may have been supplied due to the request of the equipment end user. Consult Thermal Solutions for repair parts on non-standard controls and components.

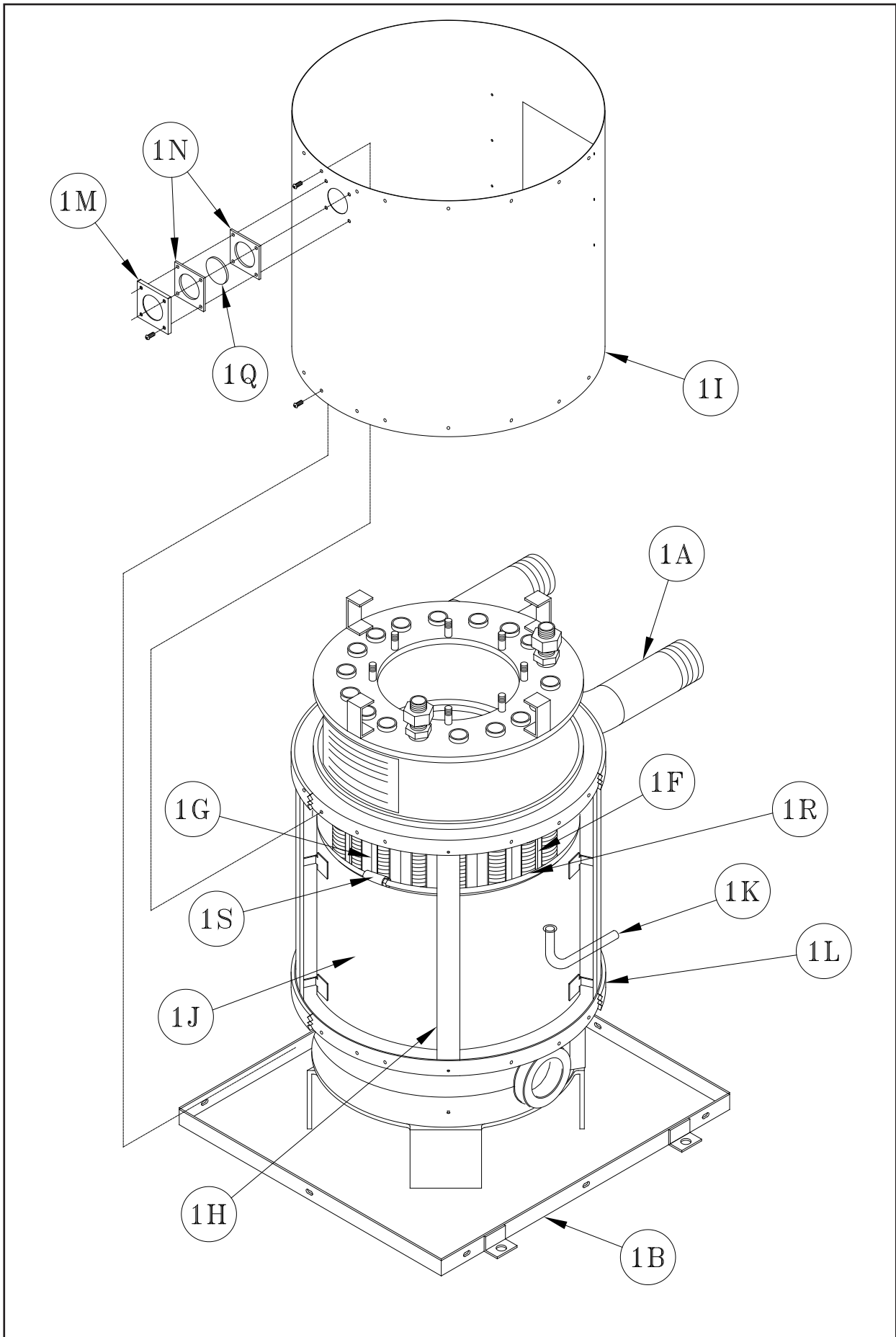

Figure 19: Boiler Combustion Chamber

BOILER COMBUSTION CHAMBER						
Key No.	Description	(Quantity) Part Number				
		EVCA-750	EVCA-1000	EVCA-1500	EVCA-2000	EVCA-3000
1. COMBUSTION CHAMBER ASSEMBLY						
1A	Heat Exchanger	(1) 603EVC07510	(1) 603EVC01000	(1) 603EVC01500	(1) 6035630061	(1) 104057-01
1B	Base	(1) 61556024				(1) 103078-01
1F	Tube Baffle	(31) 70356215	(31) 70356216	(31) 70356217	(31) 70356218	(41) 70356317
1G	Sight Tube Baffle	(1) 70356223	(1) 70356224	(1) 70356225	(1) 70356226	(1) 70356320
1H	Combustion Pan Support	(4) 603562041	(4) 603562051	(4) 603562061	(4) 603562071	(6) 60356210
1I	Heat Exchanger Wrapper	(1) 804EVC2003	(1) 804EVC2004	(1) 804EVC2005	(1) 804EVC2006	(1) 103081-02
1J	Heat Exchanger Baffle	(1) 70356236	(1) 70356237	(1) 70356238	(1) 70356239	(1) 70356242
1K	Condensate Drain Tube	(1) 806EVC01			(1) 8065601	
1L	1" Fiber Gasket	(14 LF) 9206032				(19.5) 9206032
1M	Sight Glass Lens Retainer	(1) 7186019				
1N	Sight Glass Gaskets	(2) 8206039				
1Q	Sight Glass Lens	(1) 8026082				
1R	Wrapper Banding	(24 LF) 92466028				(25.5 LF) 92466028
1S	Banding Buckle	(4) 80860946				
1T	Temperature Probe (not shown)	(2) 101935-01				

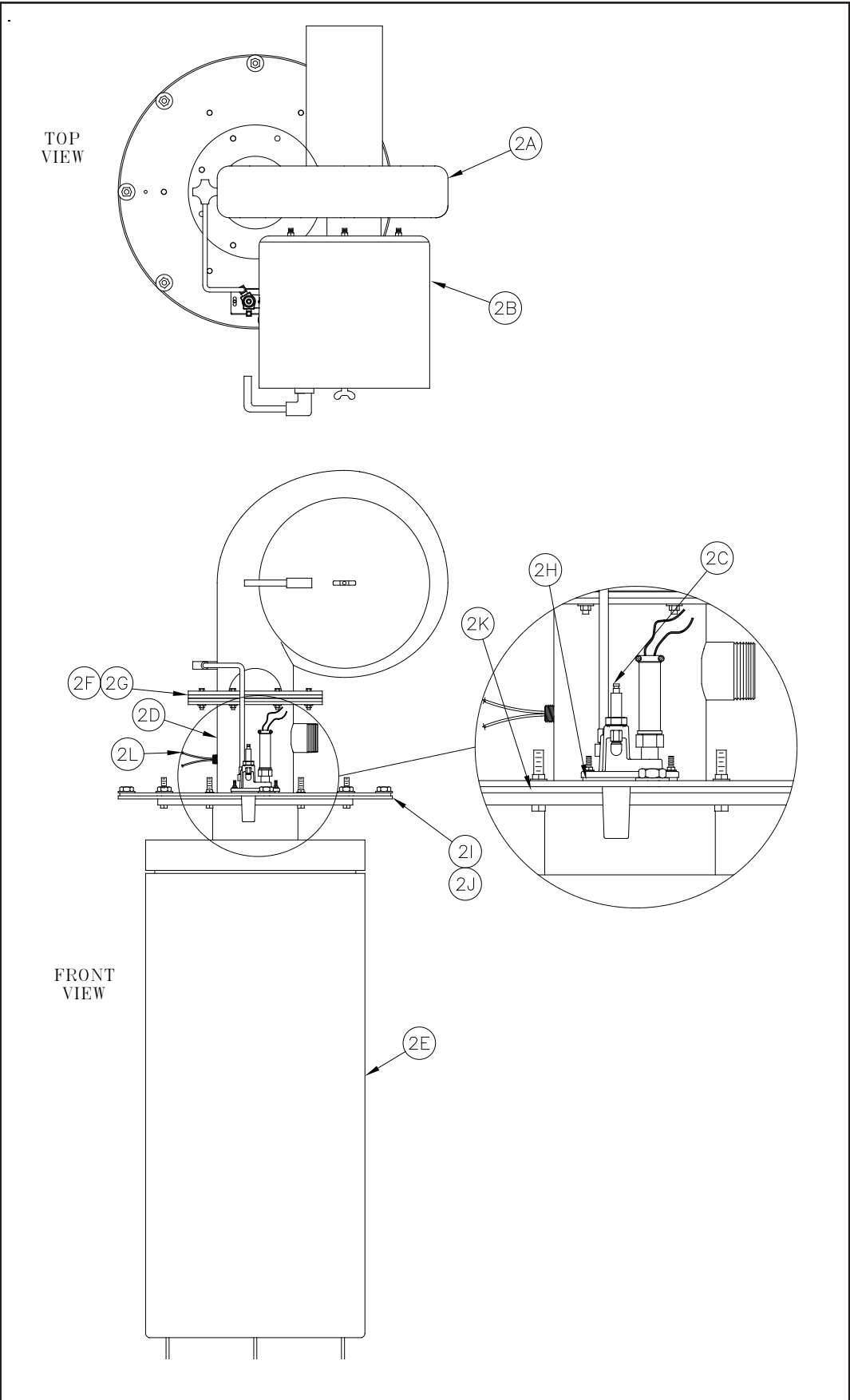

Figure 20: Burner Assembly

BURNER ASSEMBLIES						
Key No.	Description	(Quantity) Part Number				
		EVCA-750	EVCA-1000	EVCA-1500	EVCA-2000	EVCA-3000
2. BURNER/ FAN ASSEMBLY						
2A	Fan (three phase)	(1) 81156018				(1) 81156300
2B	Air Filter	(1) 81156011			(1) 81156012	(1) 81156101
2C	Pilot Assembly - Natural -OR- Pilot Assembly -LP	See Figure 27				
2D	Mixer Assembly - Natural	(1) 60256209	(1) 60256210	(1) 60256211	(1) 60256212	(1) 62156300
	Mixer Assembly - LP	(1) 60256213	(1) 60256214	(1) 60256215	(1) 60256216	(1) 62156300
2E	Burner Element	(1) TS750CF- GBNR	(1) TS1000CF- GBNR	(1) TS1500CF- GBNR	(1) TS2000CF- GBNR	(1) TS3000CF- GBNR
2F	Air Orifice Gasket	(2) 8205603				(2) 8205666
2G	Air Orifice	(1) 80256235	(1) 80256236	(1) 80256237	N/A	
2H	Pilot Gasket	(1) 8205608				
2J	Burner Gasket	(1) 82056041				(1) 82056501
2K	Burner Mounting Flange Gasket	(1) 8205605				(1) 8205665
2L	Burner Thermal Fuse Assembly	(1) 6025601				N/A

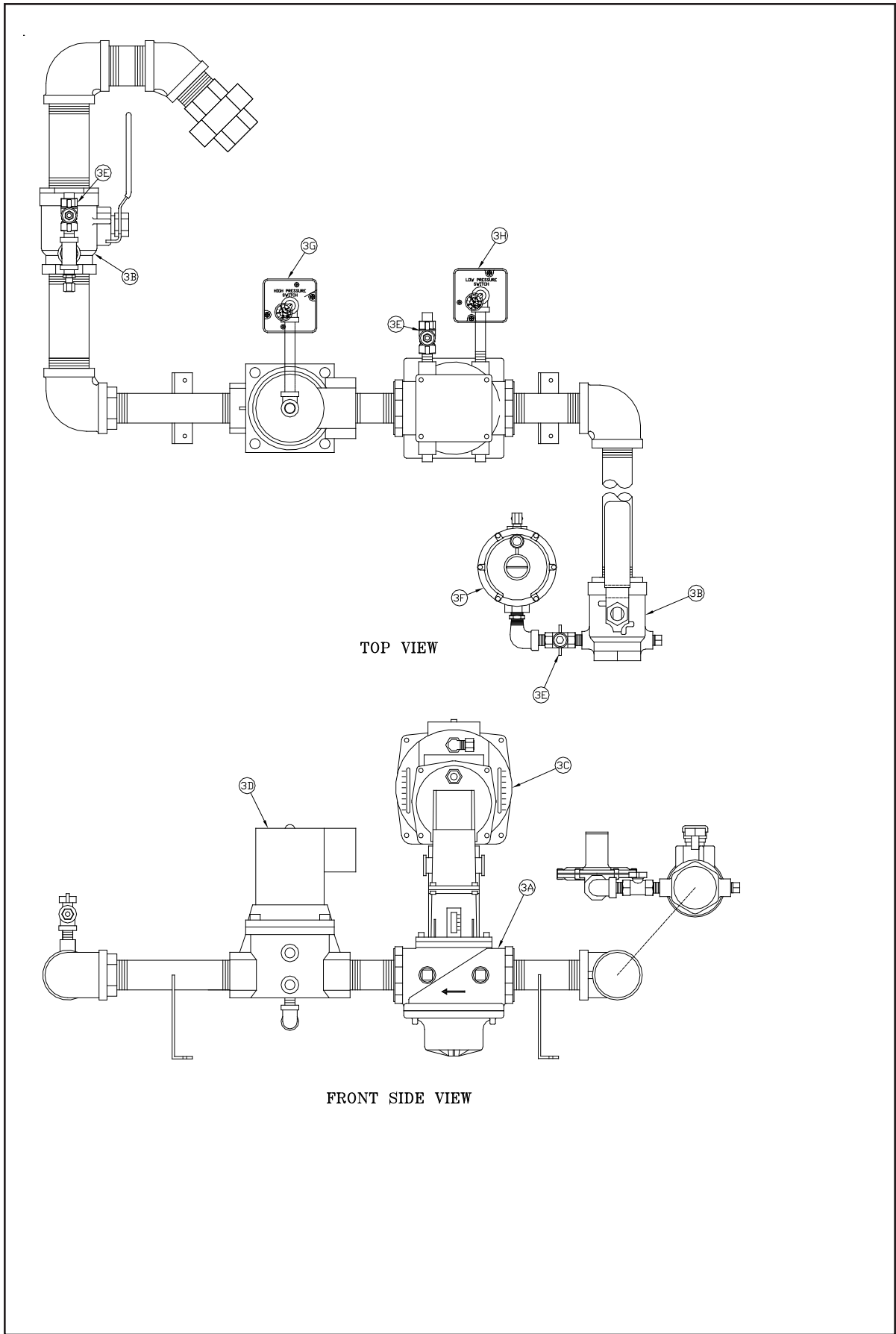

Figure 21a: UL/FM/CSD-1 Main Gas Train Assembly (EVCA-750/2000)

UL/FM/CSD-1 GAS TRAIN - MAIN AND PILOT					
Key No.	Description	(Quantity) Part Number			
		EVCA-750	EVCA-1000	EVCA-1500	EVCA-2000
3. MAIN AND PILOT GAS TRAIN (UL/FM/CSD-1)					
3A	Main Gas Valve Body, 1" NPT	(1) 816634041	---	---	---
	Main Gas Valve Body, 1½" NPT	---	(1) 81663404		
3B	Manual Gas Valve with Pilot Tapping, 1" NPT	(1) 806603055	---	---	---
	Manual Gas Valve with Pilot Tapping, 1½" NPT	(1) 806603053	(2) 806603053		
3C	Air/Gas Ratio Controller, Siemen's SKP75	(1) 81663408			
3D	Solenoid Valve V4295A1031, 1" NPT	(1) 81660207	---	---	---
	Solenoid Valve V4295A1056, 1½" NPT	---	(1) 81660205		
3E	Manual Gas Cock, ¼"	(3) 822758			
3F	Pilot Gas Regulator	(1) 822702			
3G	High Gas Pressure Switch	(1) 80160333			
3H	Low Gas Pressure Switch	(1) 80160332			

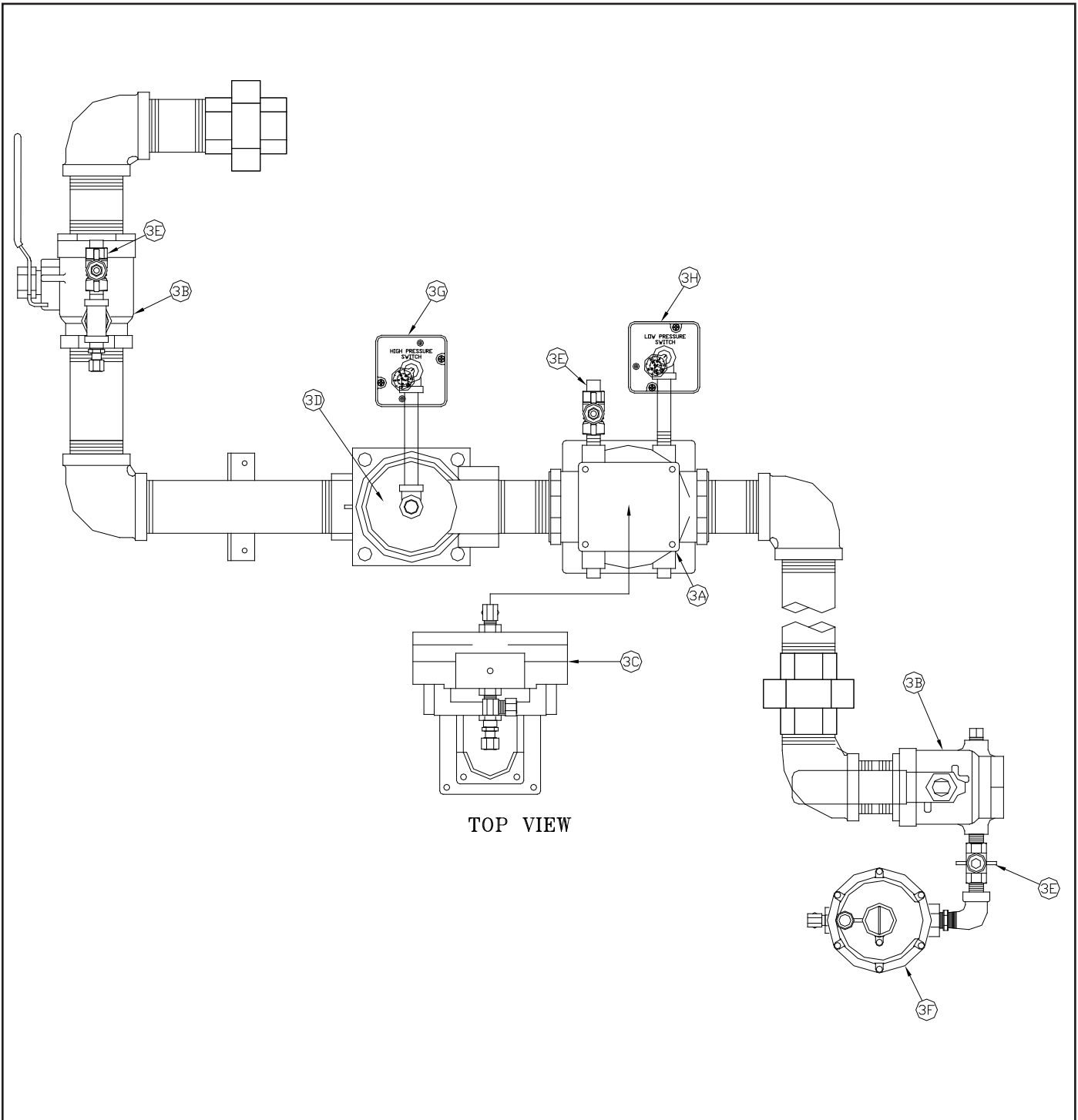

Figure 21b: UL/FM/CSD-1 Main Gas Train Assembly (EVCA-3000)

UL/FM/CSD-1 Gas Train - Main and Pilot		
Key No.	Description	(Quantity) Part Number
		EVCA-3000
Main and Pilot Gas Train (UL/FM/CSD-1)		
3A	Main Gas Valve Body, 2" NPT	(1) 816634043
3B	Manual Gas Valve Body with Pilot Tapping, 2" NPT	(2) 806604691
3C	Air/Gas Ratio Controller, Siemens SKP75	(1) 81663408
3D	Solenoid Valve V4295A1064, 2" NPT	(1) 816602051
3E	Manual Gas Cock, 1/4"	(3) 822758
3F	Pilot Gas Regulator	(1) 822702
3G	High Gas Pressure Switch	(1) 80160333
3H	Low Gas Pressure Switch	(1) 80160322

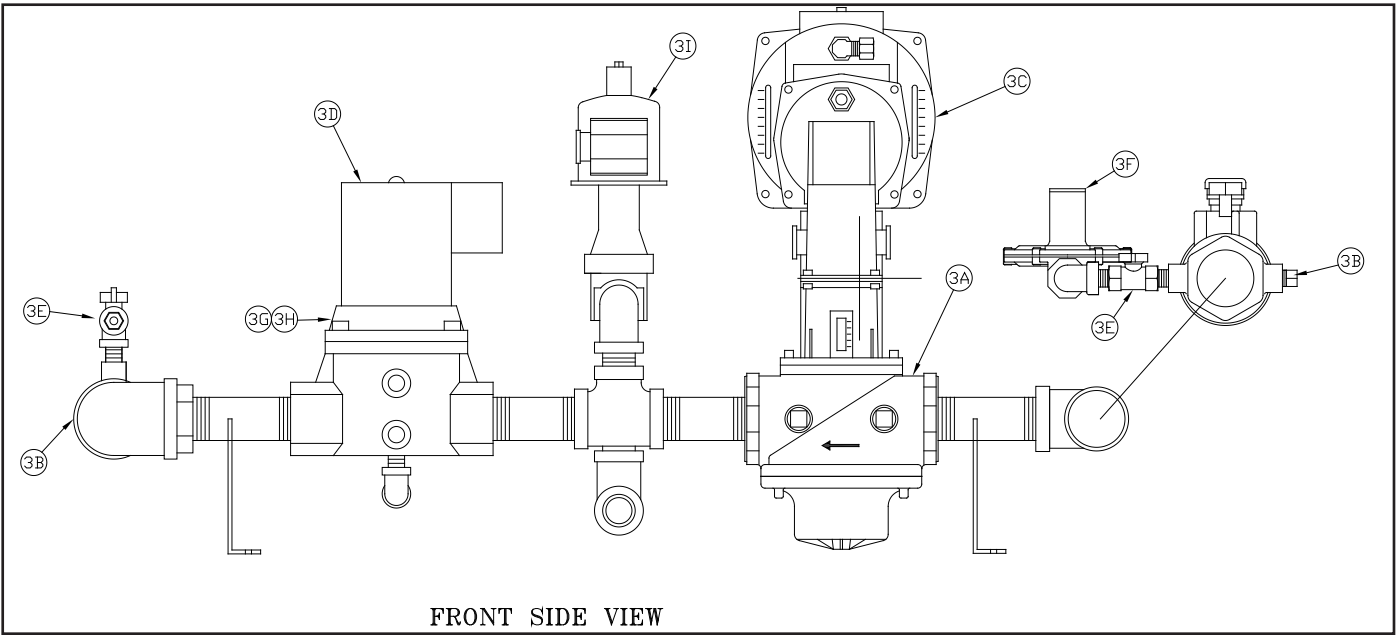

Figure 22a: DB&B Gas Train (750)

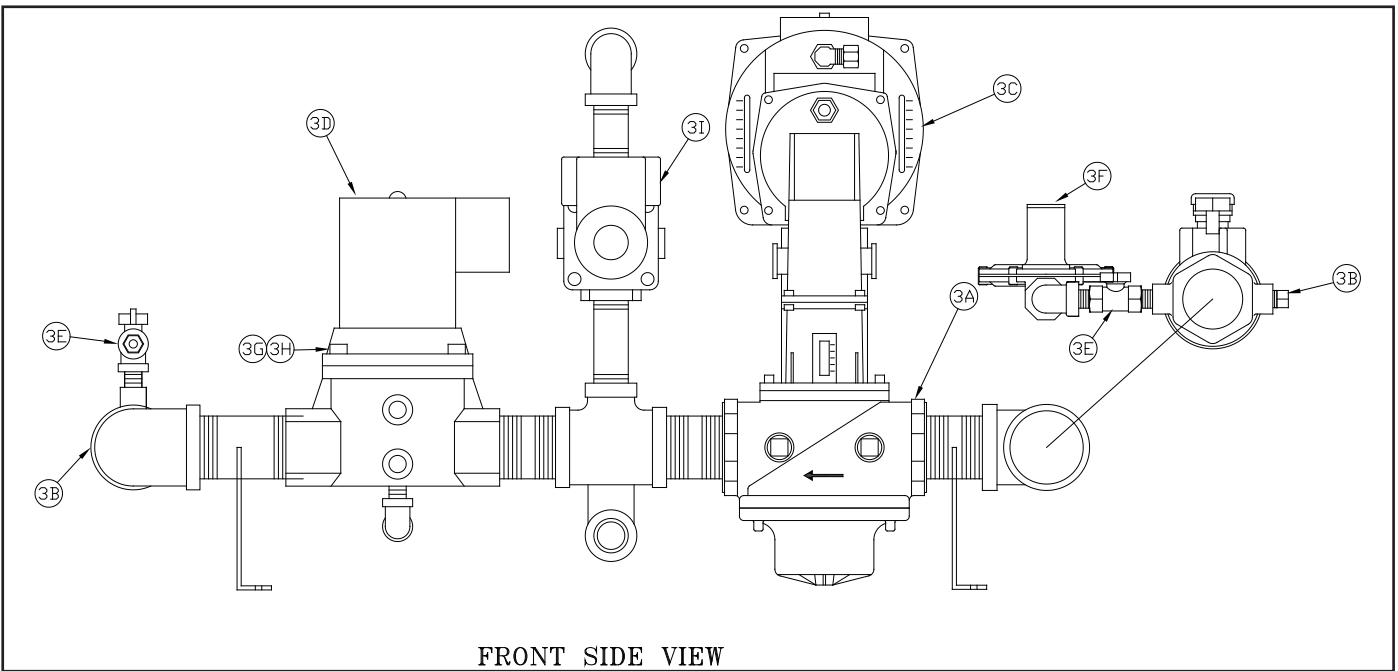

Figure 22b: DB&B Gas Train (1000-2000)

DB&B – MAIN AND PILOT					
Key No.	Description	(Quantity) Part Number			
		EVCA-750	EVCA-1000	EVCA-1500	EVCA-2000
3. MAIN AND PILOT GAS TRAIN					
3A	Main Gas Valve Body 1" NPT	(1) 816634041	—	—	—
	Main Gas Valve Body, DBL, 1-1/2" NPT	—	(1) 81663404		
3B	Manual Gas Valve with Pilot Tapping, 1" NPT	(1) 806603055	—	—	—
	Manual Gas Valve with Pilot Tapping, 1-1/2" NPT	(1) 806603053	(2) 806603053		
3C	DB&B Actuator/Regulator Ratio Valve, Siemens SKP75 (max 5 PSI)	(1) 81663408			
3D	DB&B Solenoid Valve	(1) 81660207	(1) 81660205		
3E	Manual Gas Cock, 1/4"	(3) 822758			
3F	Pilot Gas Regulator	(1) 822702			
3G	High Gas Pressure Switch	(1) 80160333			
3H	Low Gas Pressure Switch	(1) 80160332			
3I	Normally Open Vent Valve	(1) 81660748			

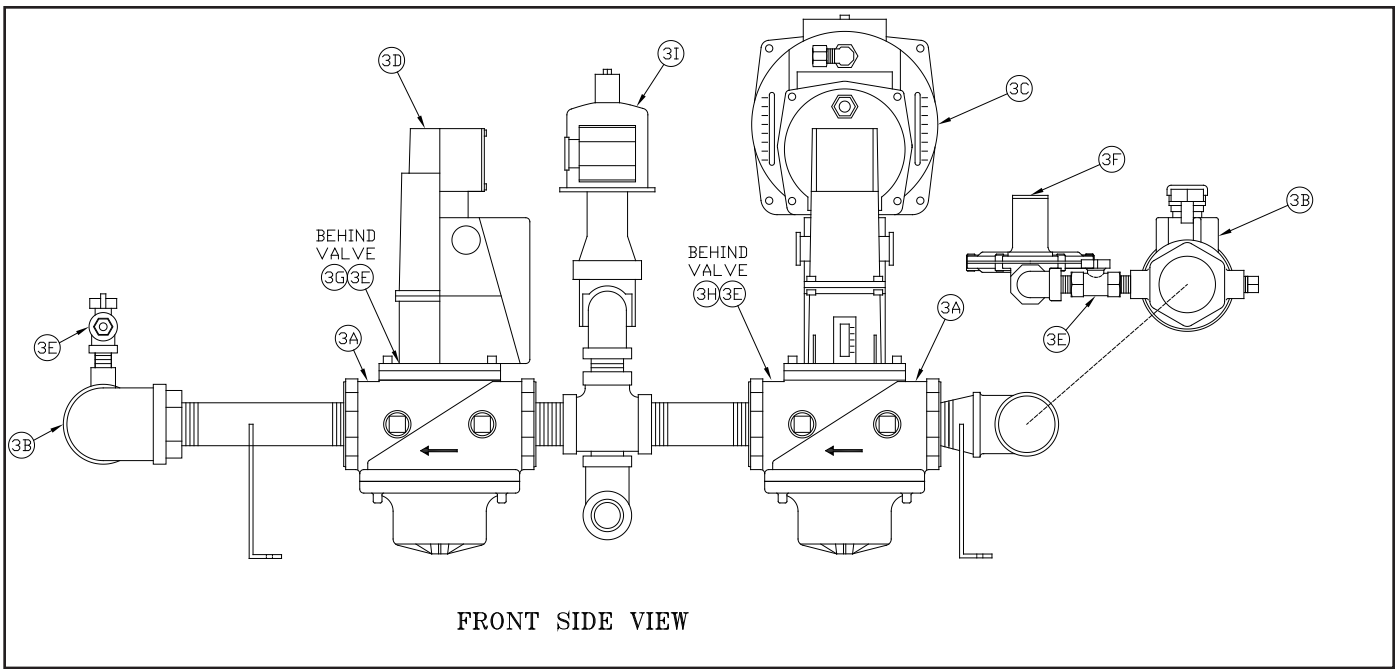

Figure 22c: DB&B w/POC Gas Train (750)

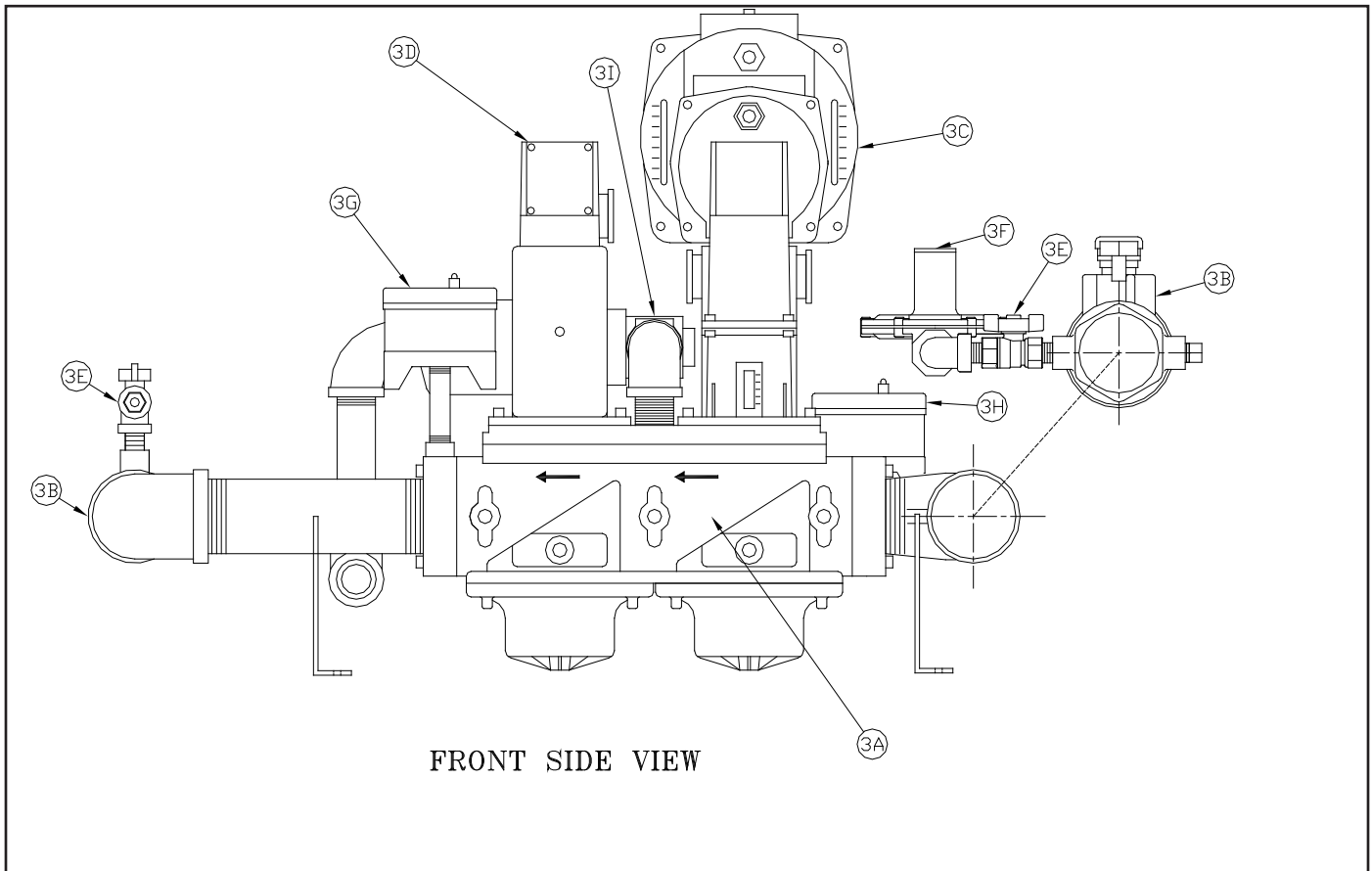

Figure 22d: DB&B w/POC Gas Train (1000-2000)

DB&B W/POC – MAIN AND PILOT					
Key No.	Description	(Quantity) Part Number			
		EVCA-750	EVCA-1000	EVCA-1500	EVCA-2000
3. MAIN AND PILOT GAS TRAIN					
3A	Main Gas Valve Body 1" NPT	(2) 816634041	—	—	—
	Main Gas Valve Body, DBL, 1-1/2" NPT	—	(1) 81663404		
3B	Manual Gas Valve with Pilot Tapping, 1" NPT	(1) 806603055	—	—	—
	Manual Gas Valve with Pilot Tapping, 1-1/2" NPT	(1) 806603053	(2) 806603053		
3C	DB&B w/POC Actuator/Regulator Ratio Valve, Siemens SKP75 (max 5 PSI)	(1) 81663409			
3D	DB&B w/POC Actuator, Siemens SKP15	(1) 81663407			
3E	Manual Gas Cock, 1/4"	(3) 822758			
3F	Pilot Gas Regulator	(1) 822702			
3G	High Gas Pressure Switch	(1) 80160333			
3H	Low Gas Pressure Switch	(1) 80160332			
3I	Normally Open Vent Valve	(1) 81660748			

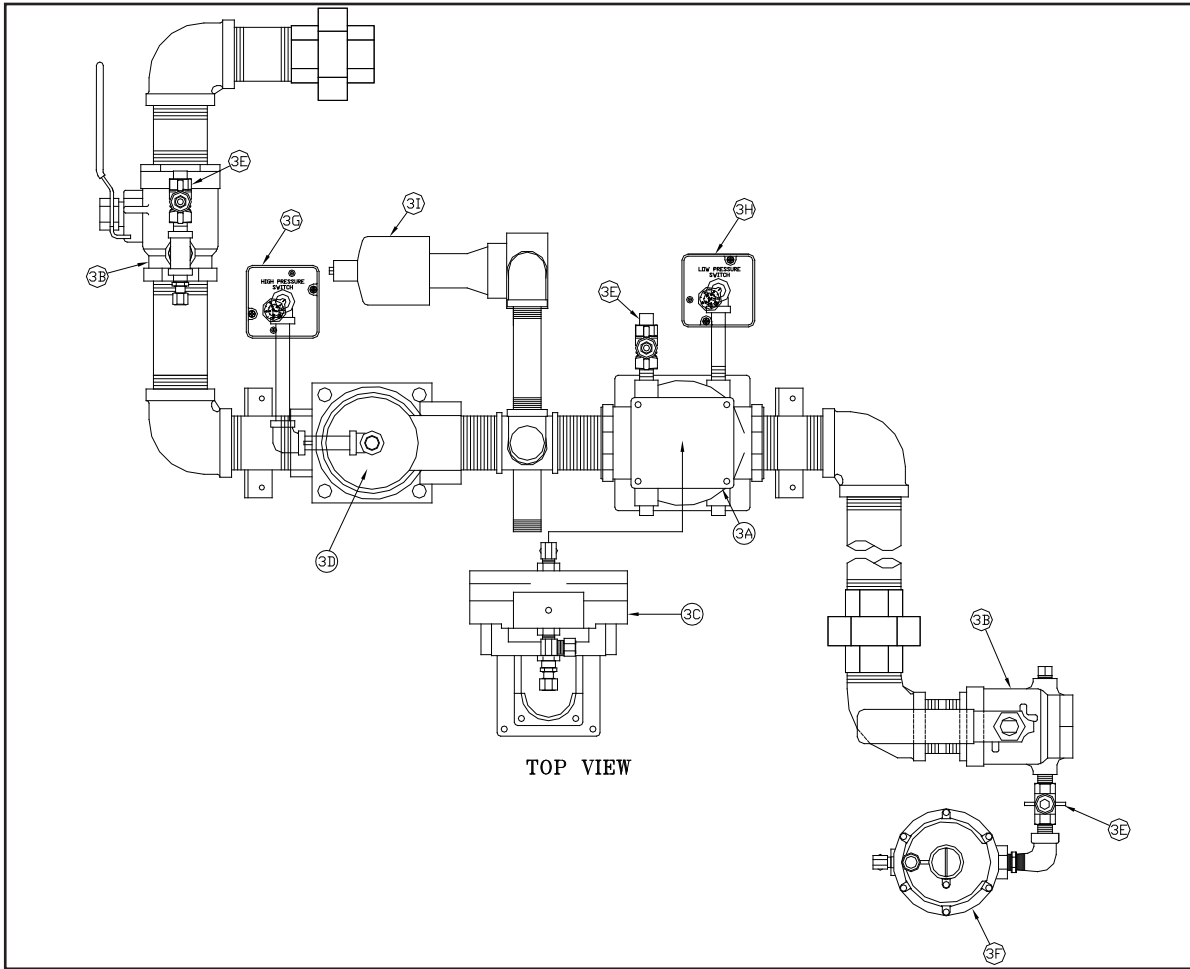

Figure 22e: DB&B Gas Train (EVCA-3000)

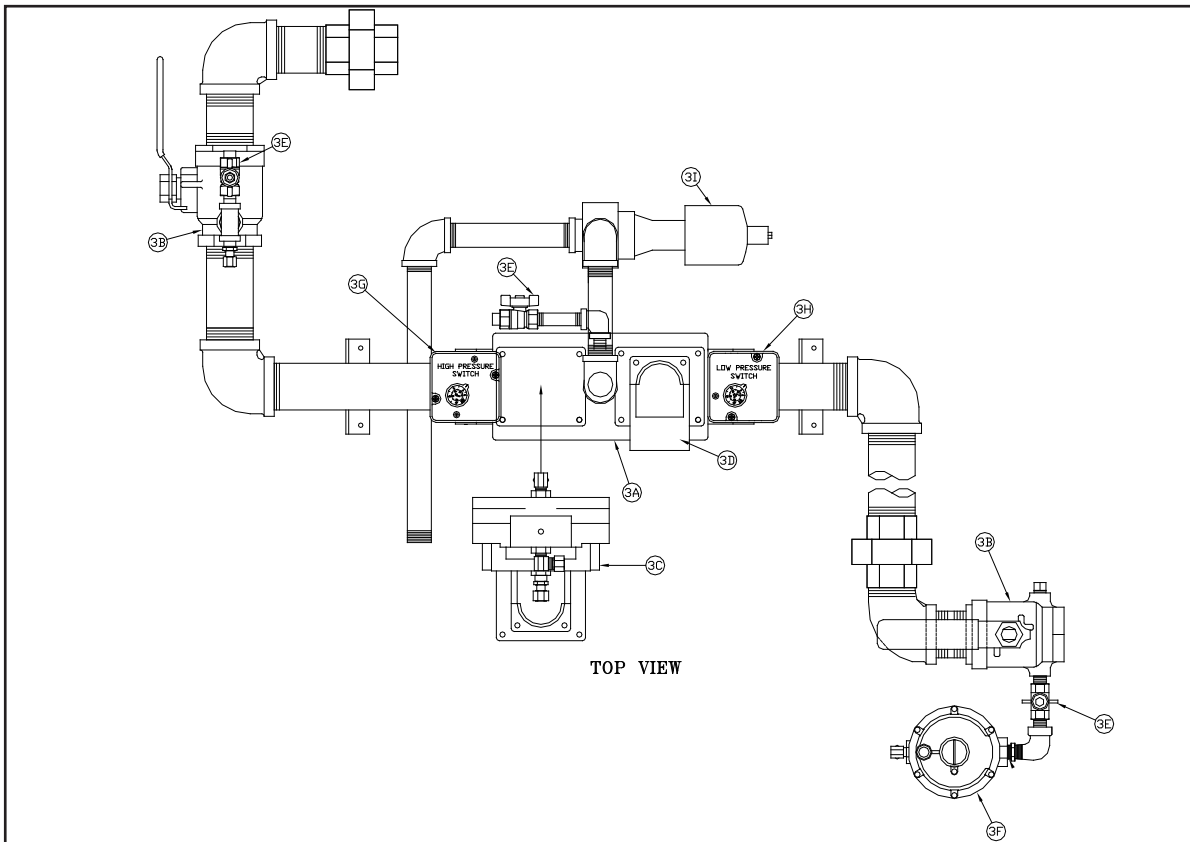

Figure 22f: DB&B w/POC Gas Train (EVCA-3000)

DB&B AND DB&B W/POC - MAIN AND PILOT		
Key No.	Description	(Quantity) Part Number
		EVCA-3000
3. MAIN AND PILOT GAS TRAIN		
3A	Main Gas Valve Body, DB&B, 2" NPT	(1) 816634043
	Main Gas Valve Body, DB&B w/POC, 2" NPT	(1) 816634051
3B	Manual Gas Valve with Pilot Tapping	(2) 80660491
3C	DB&B Actuator/Regulator Ratio Valve, Siemens SKP75 (max 5 psi)	(1) 81663408
	DB&B w/POC Actuator/Regulator Ratio Valve Siemens SKP75 (max 5 psi)	(1) 81663409
3D	DB&B Solenoid Gas Valve, Honeywell	(1) 8016602051
	DB&B w/POC Actuator, Siemens SKP15	(1) 81663407
3E	Manual Gas Cock	(3) 822758
3F	Pilot Gas Regulator	(1) 822702
3G	High Gas Pressure Switch	(1) 80160333
3H	Low Gas Pressure Switch	(1) 80160332
3I	Normally Open Vent Valve	(1) 816607501

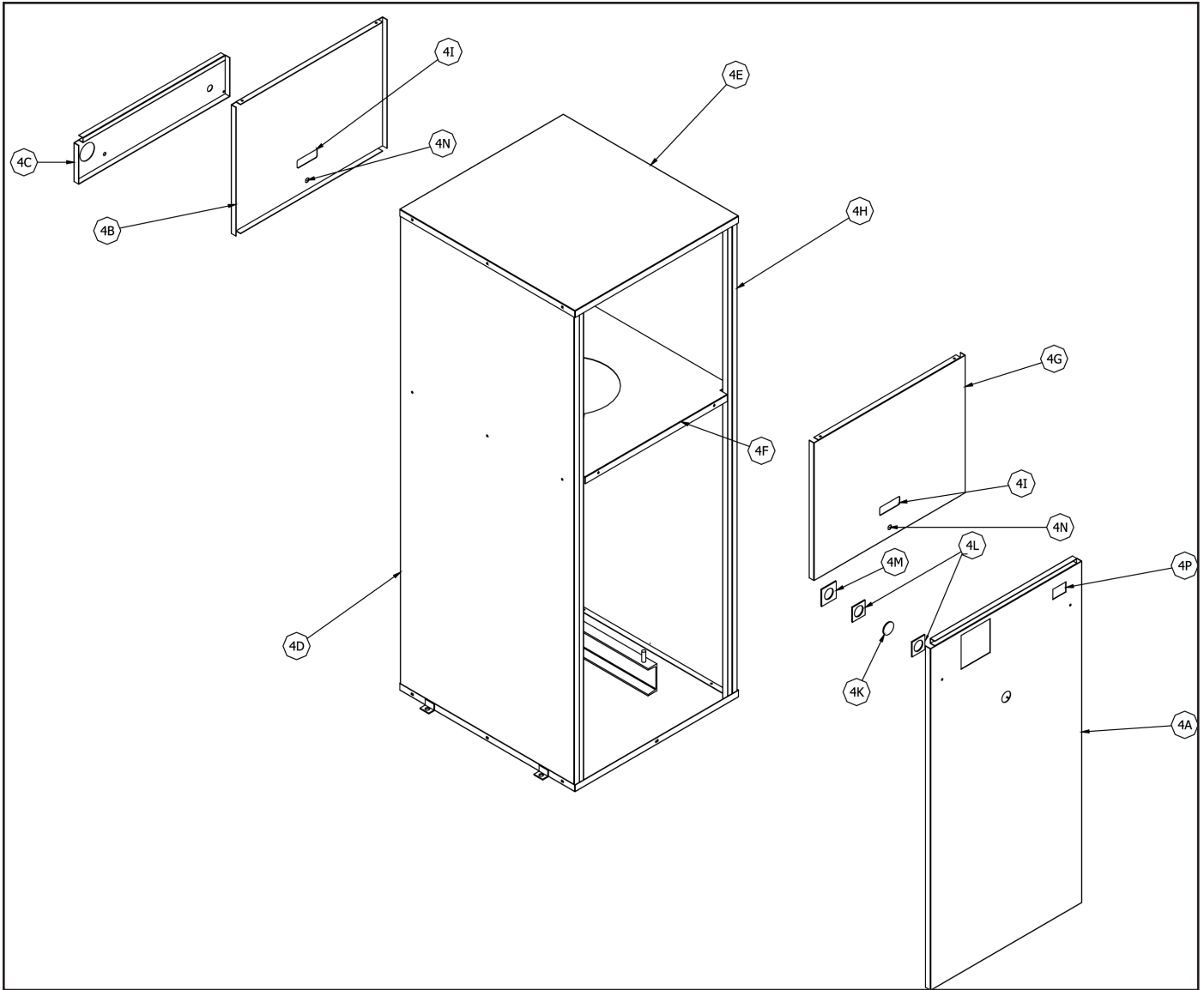

Figure 23: Jacket

JACKET						
Key No.	Description	(Quantity) Part Number				
		EVCA-750	EVCA-1000	EVCA-1500	EVCA-2000	EVCA-3000
4. JACKET ASSEMBLY						
4A	Jacket Lower Front Panel	(1) 60456342	(1) 60456343	(1) 60456344	(1) 60456345	(1) 104002-01
4B	Jacket Upper Rear Panel	(1) 70456279				(1) 704563002
4C	Jacket Center Rear Panel	---	(1) 704562471			(1) 104001-01
4D	Jacket Panel Left Side	(1) 604563291	(1) 604563301	(1) 604563311	(1) 604563321	(1) 6045603010
4E	Jacket Top Panel	(1) 704562541				(1) 704563000
4F	Jacket Vestibule Panel	(1) 604563021				(1) 604563000
4G	Jacket Upper Front Panel	(1) 70456280				(1) 104023-01
4H	Jacket Panel Right Side	(1) 604563231	(1) 604563241	(1) 604563251	(1) 604563261	(1) 6045603020
4I	Handle	(2) 8056256				
4K	Observation Port Lens	(1) 8026082				
4L	Observation Port Gasket	(2) 8206039				
4M	Observation Port Lens Retainer	(1) 7186019				
4N	Latch	(2) 80861722				
4P	Power Switch w/Filter Light	(1) 8136363				

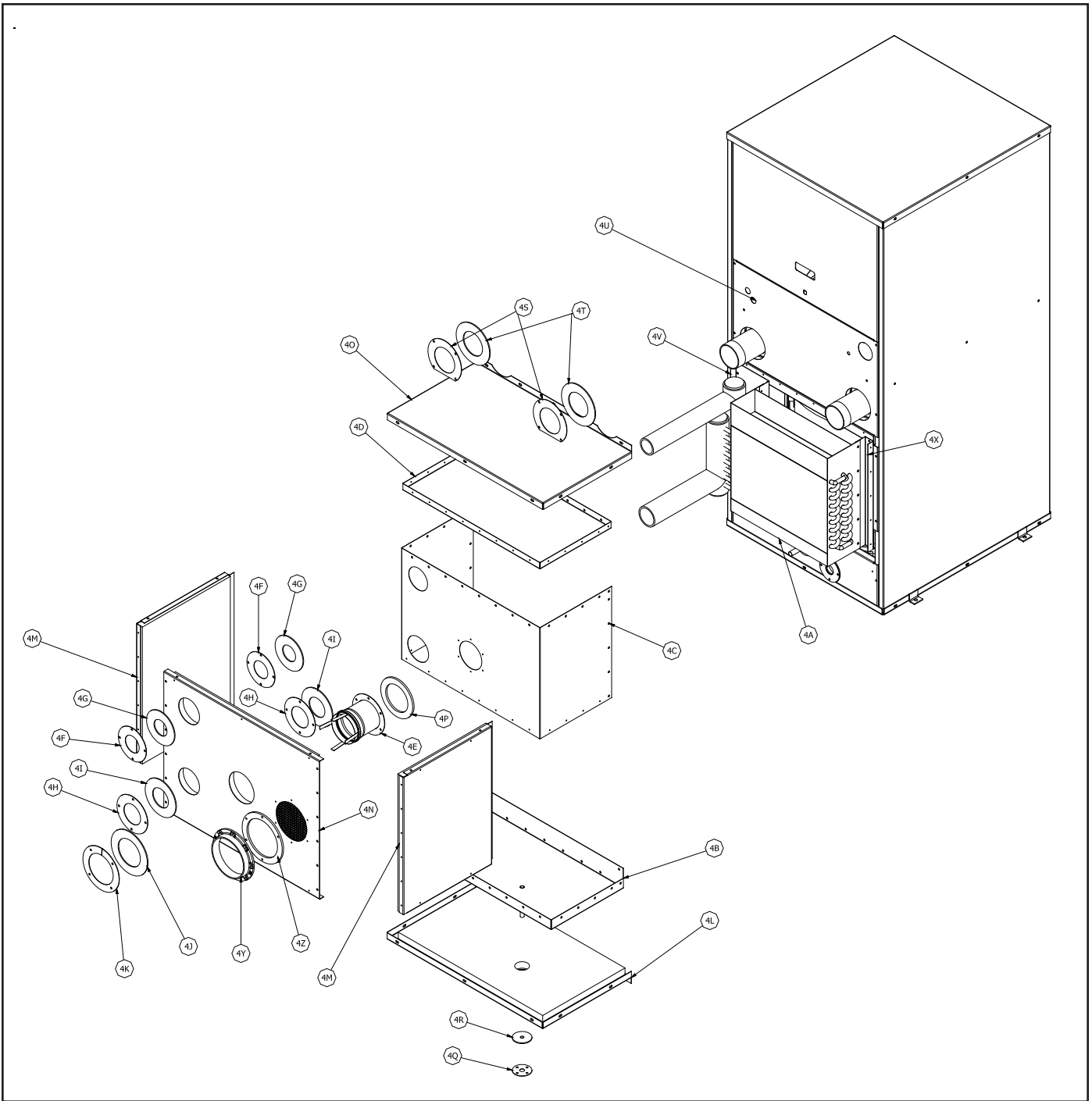

Figure 24: EVCA-750, 1000 and 1500 Secondary Heat Exchanger and Housing

EVCA-750/1500 SECONDARY HEAT EXCHANGER AND HOUSING

Key No.	Description	(Quantity) Part Number		
		EVCA-750	EVCA-1000	EVCA-1500
4. Secondary Heat Exchanger Housing				
4A	Secondary Heat Exchanger	(1) 803EVC10751	(1) 803EVC11001	(1) 803EVC11501
4B	Secondary Heat Exchanger Drain Pan	(1) 703EVC211		
4C	Secondary Heat Exchanger Wrapper	(1) 703EVC2003	(1) 703EVC2004	(1) 703EVC2005
4D	Secondary Heat Exchanger Top Pan	(1) 703EVC20021		
4E	Stack Adapter	(1) 811EVC004	(1) 811EVC006	
4F	2" Trim Ring	(2) 70456271		
4G	2" Trim Ring Gasket	(2) 8205643		
4H	2-1/2" Trim Ring	(2) 704EVC001		
4I	2-1/2" Trim Ring Gasket	(2) 8205676		
4J	Stack Adapter Gasket	(1) 8205641	(1) 8205642	
4K	Stack Adapter Trim Ring	(1) 70456121	(1) 70446129	
4L	Secondary Heat Exchanger Jacket Bottom Panel	(1) 604EVC220401		
4M	Secondary Heat Exchanger Jacket Side Panel	(2) 604EVC22010	(2) 604EVC22011	(2) 604EVC22012
4N	Secondary Heat Exchanger Jacket Back Panel	(1) 604EVC22020	(1) 604EVC22021	(1) 604EVC22022
4O	Secondary Heat Exchanger Jacket Top Panel	(1) 604EVC220301		
4P	Stack Trim Ring Gasket	(1) 820EVC01	(1) 820EVC02	
4Q	1/2" Condensate Trim Ring	(1) 704EVC002		
4R	1/2" Condensate Trim Ring Gasket	(1) 8205677		
4S	3" Trim Ring	(2) 704EVC004	(2) 70456272	
4T	3" Trim Ring Gasket	(2) 8205644		
4U	Jacket Center Rear Panel	(1) 604EVC21010	(1) 604EVC21011	(1) 604EVC21012
4V	Secondary Heat Exchanger Left Mounting Bracket	(1) 703EVC26	(1) 703EVC27	(1) 703EVC28
4X	Secondary Heat Exchanger Right Mounting Bracket	(1) 703EVC22	(1) 703EVC23	(1) 703EVC24
4Y	Air Inlet Trim Ring	(1) 81156106		(1) 81156108
4Z	Air Inlet Trim Ring Gasket	(1) 82056106		(1) 82056108

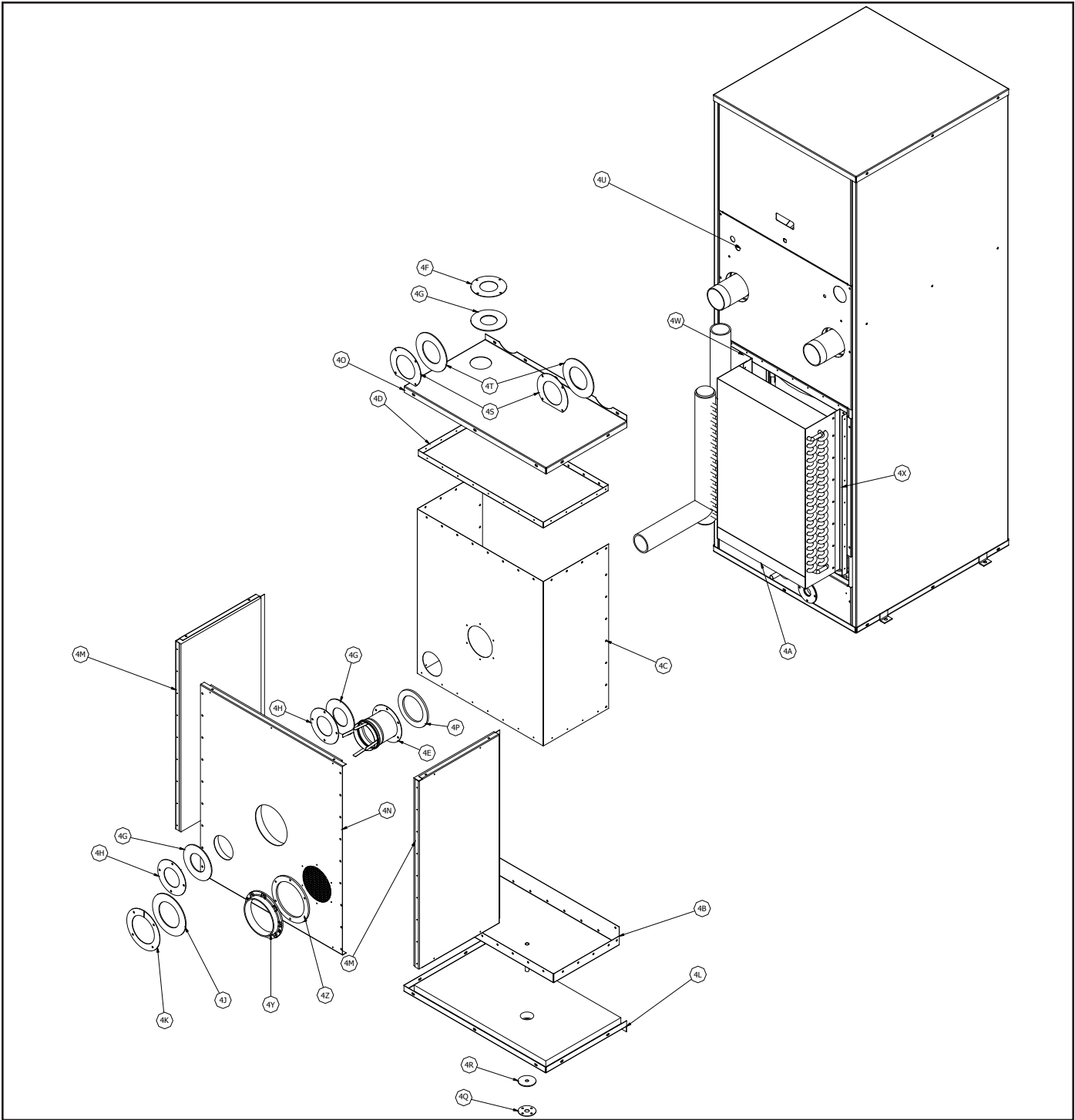

Figure 25a: EVCA-2000 Secondary Heat Exchanger and Housing

EVCA-2000 SECONDARY HEAT EXCHANGER AND HOUSING		
Key Number	Description	(Quantity) Part Number
		EVCA-2000
4. EVCA-2000 Secondary Heat Exchanger Housing		
-	Boiler Drain Trim Ring, 1" (not shown)	(1) 70456136
-	Boiler Drain Trim Ring Gasket, 1" (not shown)	(1) 8205651
4A	Secondary Heat Exchanger	(1) 803EVC12000
4B	Secondary Heat Exchanger Drain Pan	(1) 703EVC21
4C	Secondary Heat Exchanger Wrapper	(1) 703EVC2006
4D	Secondary Heat Exchanger Top Panel	(1) 703EVC2002
4E	Stack Adapter	(1) 811EVC006
4F	Modified 2-1/2" Trim Ring	(1) 704EVC003
4G	2-1/2" Trim Ring Gasket	(4) 8205676
4H	2-1/2" Trim Ring	(3) 704EVC001
4J	Stack Adapter Gasket	(1) 8205642
4K	Stack Adapter Trim Ring	(1) 70456129
4L	Secondary Heat Exchanger Jacket Bottom Panel	(1) 604EVC22040
4M	Secondary Heat Exchanger Jacket Side Panel	(2) 604EVC22013
4N	Secondary Heat Exchanger Jacket Rear Panel	(1) 604EVC22023
4O	Secondary Heat Exchanger Jacket Top Panel	(1) 604EVC22030
4P	Stack Adapter Gasket	(1) 820EVC02
4Q	Condensate Drain Trim Ring, 1/2"	(1) 704EVC002
4R	Condensate Drain Trim Ring Gasket, 1/2"	(1) 8205677
4S	Water Trim Ring, 3"	(2) 70456272
4T	Water Trim Ring Gasket, 3"	(2) 8205644
4U	Jacket Center Rear Panel	(1) 604EVC21013
4W	Secondary Heat Exchanger Left Mounting Bracket	(1) 703EVC29
4X	Secondary Heat Exchanger Right Mounting Bracket	(1) 703EVC25
4Y	Air Inlet Ring, 8"	(1) 81156108
4Z	Air Inlet Ring Gasket, 8"	(1) 82056108

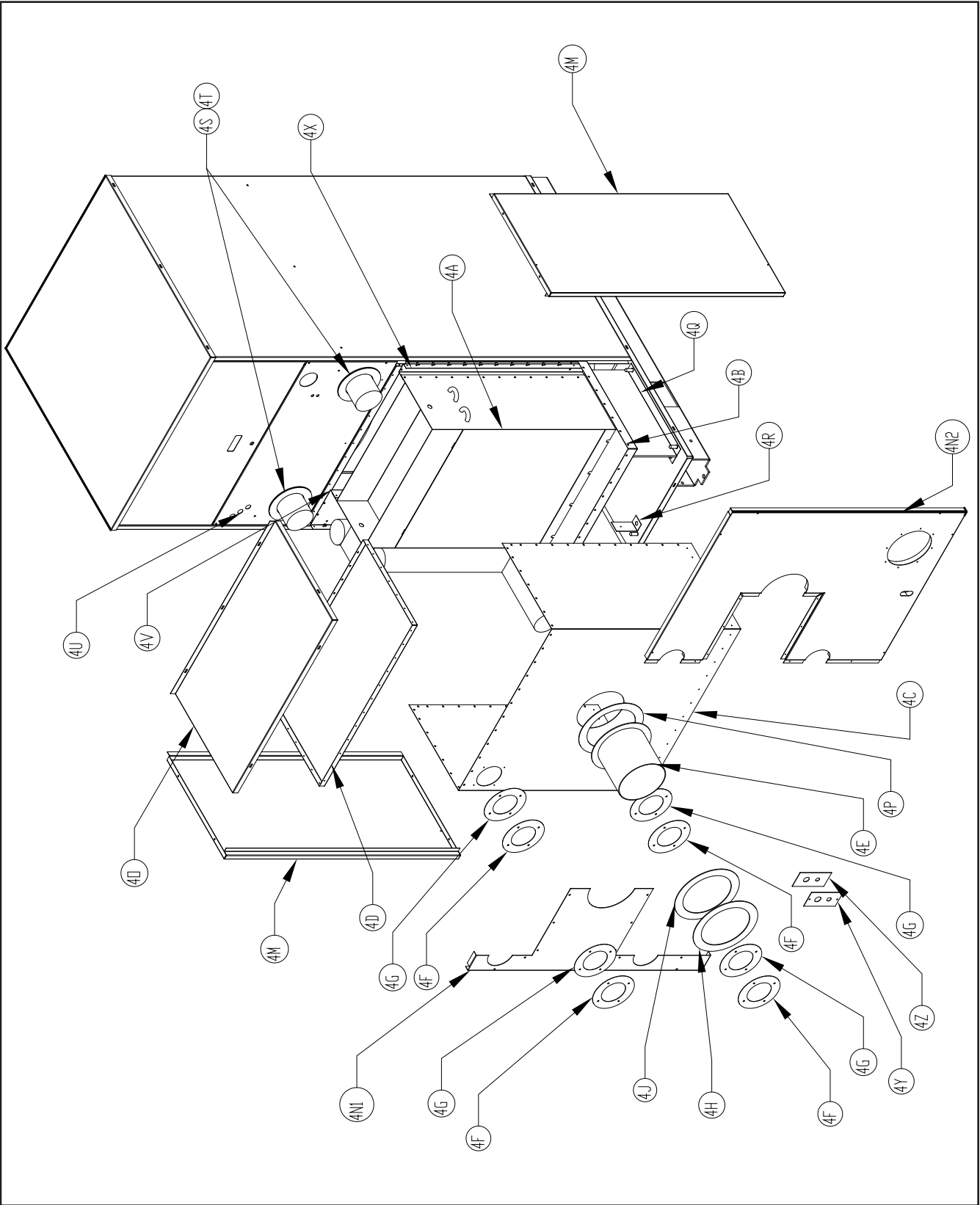

Figure 25b: EVCA-3000 Secondary Heat Exchanger and Housing

EVCA-3000 SECONDARY HEAT EXCHANGER AND HOUSING

Key No.	Description	(Quantity) Part Number
		EVCA-3000
4. Secondary Heat Exchanger Housing		
4A	Secondary Heat Exchanger	(1) 104019-01
4B	Secondary Heat Exchanger Drain Pan	(1) 103083-02
4C	Secondary Heat Exchanger Wrapper	(1) 104018-01
4D	Secondary Heat Exchanger Top Pan	(1) 104017-01
4E	Stack Adapter	(1) 811EVC008
4F	3-1/2" Trim Ring	(4) 70456150
4G	3-1/2" Trim Ring Gasket	(4) 8205678
4H	Stack Adapter Trim Ring	(1) 70456128
4J	Stack Adapter Trim Ring Gasket	(1) 8205660
4K	Air Inlet Trim Ring	(1) 81156108
4L	Air Inlet Trim Ring Gasket	(1) 82056108
4M	Secondary Heat Exchanger Jacket Side Panel	(2) 104004-01
4N1	Secondary Heat Exchanger Jacket Rear Panel, Water Side	(1) 103099-01
4N2	Secondary Heat Exchanger Jacket Rear Panel, Intake Side	(1) 103098-01
4O	Secondary Heat Exchanger Jacket Top Panel	(1) 104005-01
4P	Stack Trim Ring Gasket	(1) 820EVC03
4Q	Secondary Heat Exchanger Pan Support Brace	(2) 103079-01
4R	Condensate Line Brace	(1) 104022-01
4S	4" Trim Ring	(2) 70456131
4T	4" Trim Ring Gasket	(2) 8205661
4U	Jacket Panel, Lower Rear	(1) 104001-01
4V	Secondary Heat Exchanger Support Brace, Horn Side	(1) 104015-01
4X	Secondary Heat Exchanger Support Brace, Closed Side	(1) 104016-01
4Y	Condensate Line Trim Ring	(1) 104020-02
4Z	Condensate Line Trim Ring Gasket	(1) 104021-02
4AA	5/8" Condensate Line Extension (not shown)	(1) 104025-01
4AB	1/2" Condensate Line Hose (not shown)	(1) 103302-02
4AC	5/8" Condensate Line Extension Fitting (not shown)	(1) 104026-01

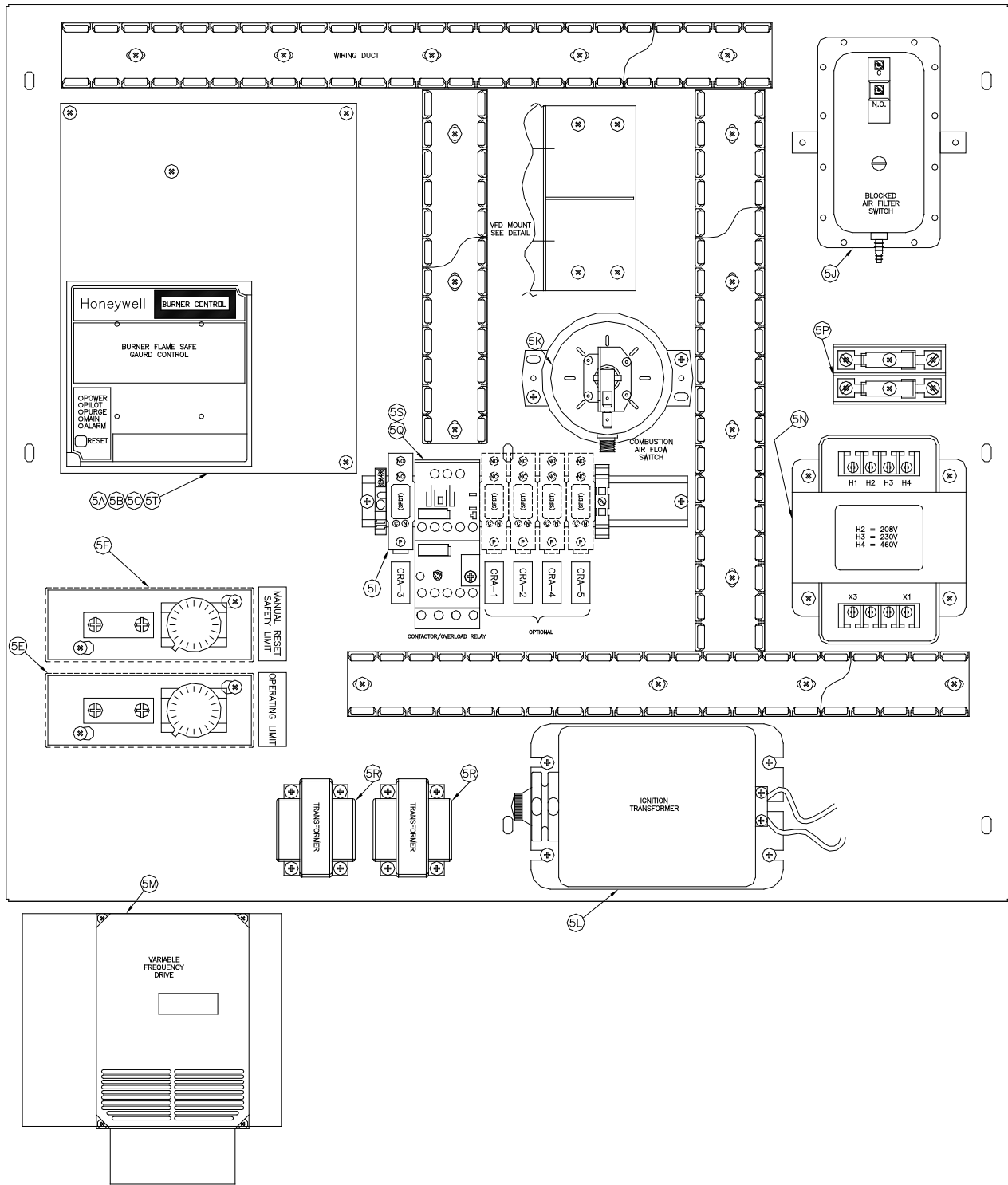

Figure 26: Control Panel Assembly

Controls		
Key No.	Description	(Quantity) Part Number
5. Controls and Components		
5A	RM7896D1027 Flame Safeguard Control for UL/FM/CSD-1/DB&B	(1) 80160212
	RM7840L1075 Flame Safeguard Control for DB&B w/POC/LFP	(1) 801602303
	Modbus Module for 5A (optional - not shown)	(1) 80160909
	Display Module for 5A (optional - not shown)	(1) 80160640
5B	Amplifier Card (not shown) R7849A1023	(1) 80160243
5C	Purge Card (not shown) ST7800A1039, UL/FM/CSD-1/DB&B/LFP	(1) 8136362
	Purge Card (not shown) ST7800A1005, DB&B w/POC	(1) 81363621
5D	Power Switch w/Filter Light (not shown)	(1) 8136363
5E	Operating Limit L4008A1015 (Auto Reset)	(1) 80160626
5F	High Limit L4008E 1313 (Manual Reset - Max 240F)	(1) 80160667
5G	Water Flow Switch FS4-3 (not shown)	(1) 80160175
5H	Vestibule Fuse Switch (not shown)	(1) 80160209
5I	Contact Relay 12V DC	(1) 80160768
5J	Blocked Filter Switch	(1) 80160295
5K	Combustion Air Flow Switch	(1) 102382-02
5L	Ignition Transformer	(1) 80160018
5M	Variable Frequency Drive 208/230 volt input	(1) 80160940
	Variable Frequency Drive 460 volt input	(1) 80160941
	Variable Frequency Drive 115/120 volt input	(1) 80160933
5N	Control Transformer	(1) 80160820
5P	Fuses and Fuse Block, for 208/230/460V Application	(2) 8136426, (2) 8136427
5Q	Overload Relay	See Table Below
5R	Transformer AT140B1206	(2) 801600502
5S	Contactactor 3PH 120 Volt Coil (see table below for permutations)	See Table Below
5T	Q7800H1109 Board for Thermal Solutions Boiler Control (TSBC™)	(1) 101182-01
5U	Thermal Solutions Boiler Control (TSBC) Assembly (not shown)	(1) 101171-03
5V	Resistor, 1K ohm, 25 watt (LFP boiler only)	(1) 103577-01
5W	Delay Timer (LFP boiler only)	(1) 80160675

Description	5Q	5S
120V - 1 Phase, EVCA-750/1000	813EVC60004	813EVC60001
208/230V - 1 Phase, EVCA-750/1000	813EVC60003	813EVC60001
208/230 - 3 Phase, EVCA-750/1000	813EVC60002	813EVC60001
120V - 1 Phase, EVCA-1500/2000	813EVC60009	813EVC60007
208/230V - 1 Phase, EVCA-1500/2000	813EVC60004	813EVC60001
208/230V - 3 Phase, EVCA-1500/2000	813EVC60003	813EVC60001
460V - 3 Phase, EVCA-750/1000	813EVC60008	813EVC60001
460V - 3 Phase, EVCA-1500/2000	813EVC60002	813EVC60001
208/230V - 3 Phase, EVCA-3000	813EVC60005	813EVC60001
460V - 3 Phase, EVCA-3000	813EVC60003	813EVC60001

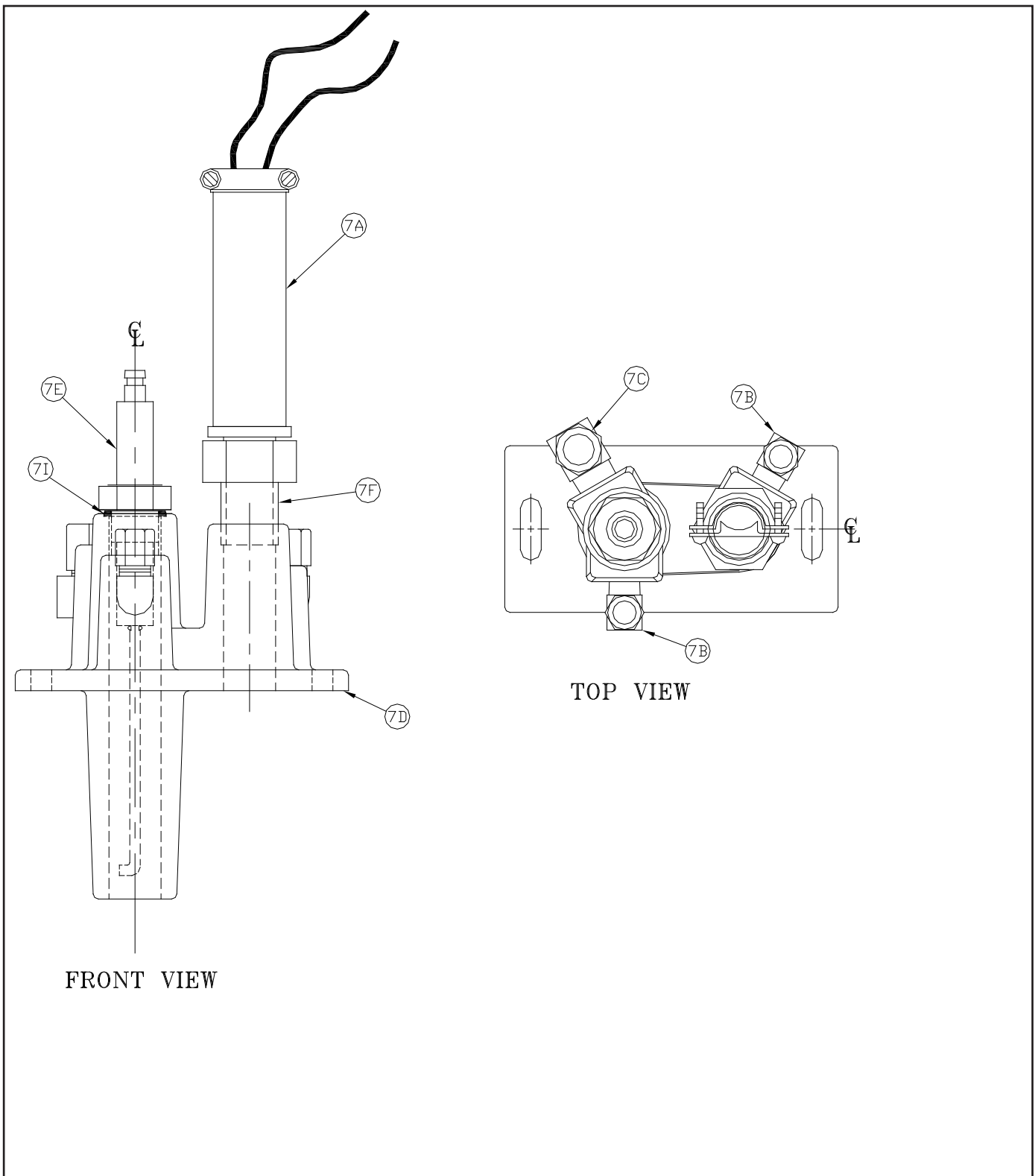

Figure 27: "Bishop" Pilot Assembly

PILOT ASSEMBLY						
Key No.	Description	(Quantity) Part Number				
		EVCA-750	EVCA-1000	EVCA-1500	EVCA-2000	EVCA-3000
6. Pilot Assembly						
---	Pilot Assembly Natural Gas, ULX2			(1) 62356110		
---	Pilot Assembly Propane, ULX2			(1) 62356210		
7A	Ultraviolet Sensor			(1) 8026145		
7B	Pilot Orifice Natural Gas			(1) 722606		
	Pilot Orifice Propane			(1) 722605		
7C	Pilot Air Orifice			(1) 722607		
7D	Cast-Iron Body			(1) 82361581		
7E	Ignitor Assembly, ULX2			(1) 82356009		
7F	Nipple, 1/2" NPT X Close			(1) 806600040		
7G	Pilot Ignition Cable (not shown)			(1) 103827-01		
7H	Pilot Solenoid Valve V4048C1047 (not shown)			(1) 81660204		
7I	O-Ring			(1) 8206054		

EVCA LOOP PIPING - MAJOR COMPONENTS

Key No.	Description	(Quantity) Part Number				
		EVCA-750	EVCA-1000	EVCA-1500	EVCA-2000	EVCA-3000
8. EVCA Loop Piping						
8A	1-Phase 120/208/230V ¼ HP Pump	(1) 805622005	—	—	—	—
	3-Phase 208/230/460V ¼ HP Pump	(1) 805622006	—	—	—	—
	1-Phase 120/208/230V ¾ HP Pump	—	(1) 805622007	—	—	—
	3-Phase 208/230/460V ¾ HP Pump	—	(1) 805622008	—	—	—
	3-Phase 208/230/460V 2 HP Pump	—	—	—	(1) 104033-02	—
8B	Temperature Probe	(1) 101935-01	—	—	—	—
8C	3-Way Valve	(1) 102653-01	—	—	—	—
8D	3-Way Valve Actuator	(1) 101894-01	—	—	—	—
8E	3-Way Valve and Actuator Assembly	—	—	—	(1) 104032-01	—

IX. Thermal Solutions Boiler Control™ (TSBC™)

A. INTRODUCTION - The intent of this section is to briefly summarize the controllers capabilities, familiarize the user with its basic features and to list the factory supplied default settings. Read the additionally supplied Factory Instruction Manual for the TSBC to learn more about the controllers features and capabilities.

1. Thermal Solutions Boiler Control™ Overview

The Thermal Solutions Boiler Control™ (TSBC™) is a complete boiler monitoring and automation system. The TSBC™ provides advanced boiler modulation, operating control, diagnostics, multiple boiler lead-lag and auxiliary device control. The TSBC™ provides advanced control features in an easy to use package.

2. Flexible, Field Selectable Control

Control modes, water system, boiler auxiliary and modulating lead/lag control features are menu selectable without the need for external programmers, lap tops or down loads. Every boiler is shipped with factory defaults that make field menu selections unnecessary unless you are applying additional control features.

3. Boiler Monitoring and Diagnostic Displays

The TSBC™'s two line by sixteen character LCD display may be used for monitoring boiler inlet and outlet, remote system and outside air temperatures, modulation rate setpoint and modulating percent and mixing valve demand percent. Additionally, the display automatically presents boiler sequence messages, alarms, hold and lockout messages. A diagnostic menu is included that provides the last 10 alarm messages and boiler inlet temperature alarm history. Boiler inlet temperature alarm history includes time and date, the lowest inlet temperature reached and the amount of time the water temperature dropped below the alarm setpoint.

4. Modulation Rate and On/Off Modes

The TSBC™ may simply control boiler modulation and on/off output based on the boiler water outlet temperature and an operator adjusted setpoint. However, using parameter selections, the TSBC™ allows the boiler modulation and on/off output to respond to remote system water and outside air temperatures, Domestic Hot Water Priority (DHWP) input or Energy Domestic Hot Water Priority (EMS) modulation rate demand, remote setpoint or remote start/stop commands. Parameter selections of remote system water temperature and remote mode determine the choice of one of six different control modes.

5. Advanced Availability

The above control modes are menu selectable options. However, if a selected sensor fails, the TSBC™ automatically changes to a control mode that will allow continued automatic operation of the boiler. For example, in the event of a remote system temperature sensor failure, the TSBC™ will automatically switch to boiler outlet temperature sensor based control.

6. Outdoor Air Reset

When selected the modulation rate setpoint is automatically adjusted based on outside air temperature. Outdoor air "reset" setpoint saves fuel by adjusting the water temperature of a heating boiler lower as the outside air temperature increases.

7. Warm Weather Shutdown (WWSD)

Some boilers are used primarily for heating buildings, and the boilers can be automatically shutdown when the outdoor air temperature is warm. When outside air temperature is above the WWSD setpoint, this function will prevent the boiler, boiler pump and/or the system pump from starting.

8. Domestic Hot Water Priority (DHWP)

Some boilers are used primarily for building space heating, but also provide heat for the domestic hot water users. When the outdoor temperature is warm, the outdoor reset setpoint may drop lower than a desirable domestic hot water temperature. When enabled and a DHWP contact input is detected, the hot water setpoint is adjusted to be greater than a field adjustable DHWP Setpoint.

9. Water Side Control Outputs

In order to maximize the life and availability of a hot water systems it may be desirable to automate mixing valves, boiler pumps, system pumps, and standby system pumps. The TSBC™ makes this type of automation totally integrated and cost effective. The control of these devices is field selectable through simple yes/no menu selections.

10. Combustion Air Side Control Outputs

Boiler room Combustion air dampers (fresh air dampers) and Vent Inducer control outputs are field selectable options.

11. Peer-To-Peer Network

The TSBC™ includes state-of-the-art modulating lead-lag sequencer for up to eight (8) boilers capable of auto rotation, outdoor reset and peer-to-peer communication. The peer-to-peer network is truly "plug and play". Communication is activated by simply connecting a RJ11 telephone line between boilers. The TSBC™ provides precise boiler coordination by sequencing boilers based on

both remote system water temperature and boiler modulation rate. For example, the lead boiler can be configured to start a lag boiler after operating above 90% modulation rate for longer than an adjustable time. The boilers are modulated in "unison" (parallel) modulation rate to ensure even heat

distribution.

12. **Modbus Communication Interface**

A factory configured RS485 Modbus interface is available for Energy Management System (EMS) or SCADA system monitoring and control.

B. FRONT PANEL DISPLAY

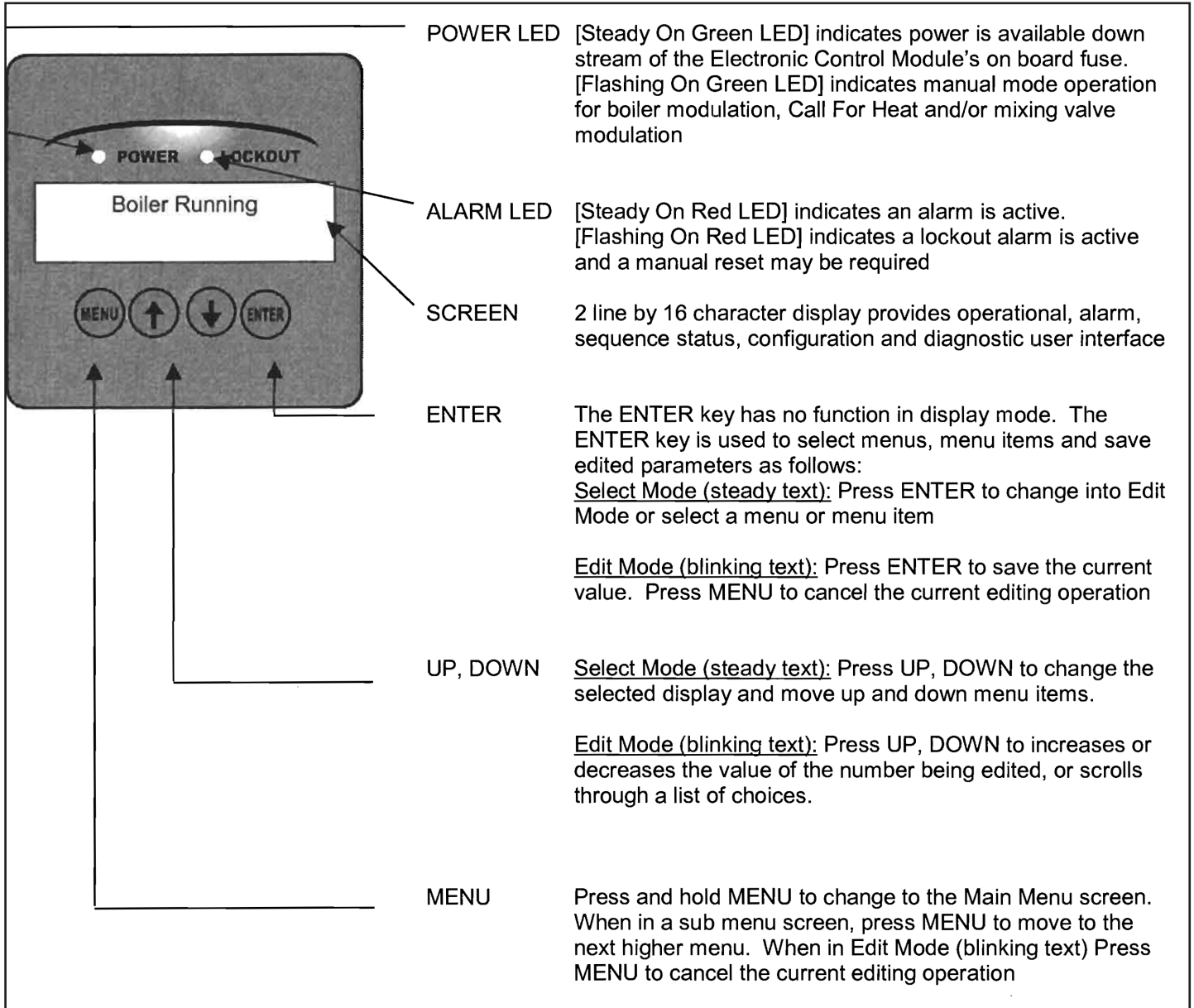

B. Thermal Solutions Boiler Control™ (TSBC™) Wiring

When wiring to the Thermal Solutions Boiler Control (TSBC™) terminals, see the terminal layout drawing on the following page or the terminal jacket label, located on the inside surface of the boiler jacket upper front panel. The TSBC™ terminals are removable for easier field wiring connection.

Label 101175-04

Thermal Solutions Boiler Control™ (TSBC™)

TERMINAL LAYOUT GUIDE

(Terminal connections as viewed from front of boiler)

Boiler Peer-To-Peer
Communication
Network



Alternate Connection For
Outside Air Temperature and
Remote System Temperature
(10k ohm Thermister, 5 Vdc)

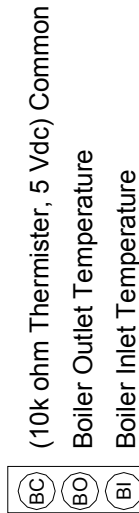

WARNING:

All connections have different inputs and outputs.
Refer to connections on diagrams for individual inputs/outputs.

NOTE:

Valid signal range for terminals C+ and C- is 1-9VDC.
See boiler wiring diagram for details.

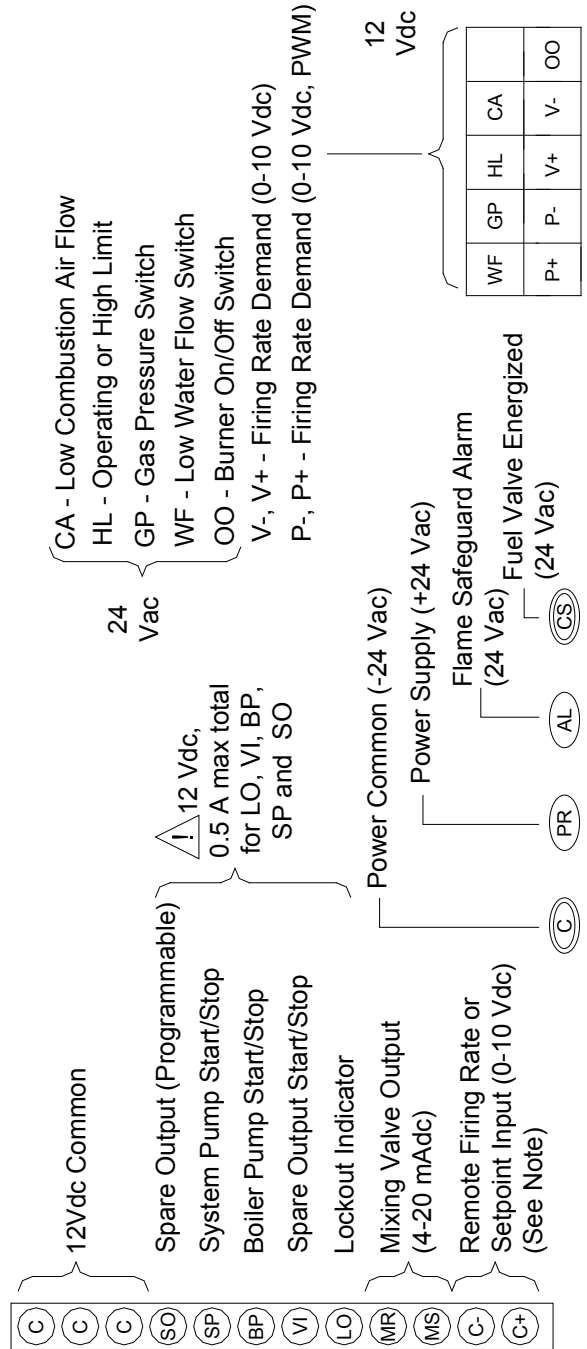

C. SECURITY MENU

1. Press and hold the MENU button to enter menu mode.
2. Access parameters and set password.
 - a. In MENU mode page through to the SECURITY menu and press ENTER.
 - b. Page down to the "Enter Password" parameter and press ENTER.
 - c. Use the arrow buttons to change the password value to the desired password and **hold** ENTER until the screen flashes.
3. The access level will reset to Basic after one hour if no key is pressed, or if power is removed.

PASSWORD

Access Level	Enter Password	Description
Basic	0 (NONE)	This is the default access level. The user can view many parameters, but is only allowed to edit a small sub-set of the parameters that are visible.
Supervisor	15	This password is set at the factory but can be changed in the field. The user can view and edit most parameters that are visible. Note: Not all parameters will be visible at the Supervisor Access Level.
Factory		All relevant internal parameters in the system will be visible and programmable. Please consult Thermal Solutions for the factory access level password.

Consult Thermal Solutions Boiler Control (TSBC) Instruction manual for operation guidance and a detailed list of parameters and their associated access levels.

D. SETUP MENU

1. Connect the boiler to the fire test heat distribution system.
2. Connect the boiler to the gas distribution system.
3. Apply the appropriate electrical power supply to the boiler (see vanilla folder for the electrical input).
4. Program the Variable Frequency Drive (VFD) according to the SCF VFD Set-Up Instruction Guide. Reference Appendix A.1 for Standard, A.2 for Low Fire Start, and A.3 for Venturi builds.
5. Program the Sage Boiler Control™ (SBC™) according to the factory settings found Appendices F – N.
6. Adjust the selector screw on top of the mixing valve actuator to the 10... 2V position. See Figure 1.

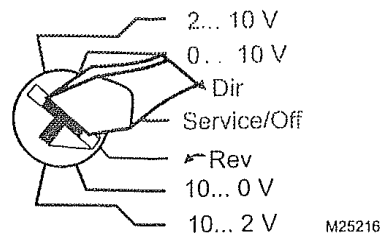

Figure 1

7. Turn the boiler on and allow for continuous operation by adjusting the heat demand via the cooling tower. Return water temperature should be above 70°F.
8. Adjust the inlet gas supply pressure to 12" W.C. with the unit running at high fire. The inlet gas supply pressure shall be measured at the manual shut off valve located at the rear of the boiler.
9. Using the methods described in the Siemens Gas Valve Set-up Procedures found on pages 2 and 3, adjust the boiler input to operate within 95-100% of the rated input at high fire and $\pm 10\%$ of the rated input at low fire. See Table

D. SETUP MENU (continued)

Display	Factory Settings	Range/Choices	Description																													
Outdoor Sensor	No	No Display Only Outdoor Reset	Enables the Outside Air Temperature sensor display and control logic. No: Outside Air Input (O+O-) is ignored. Display Only: <u>Do Not</u> Calculate setpoint based on outdoor temperature, Display Outside Air Temperature. Outdoor Reset: Calculate the temperature setpoint based on outdoor temperature using a reset curve defined by Outdoor Set Up, Boiler Set Up, Outdoor Design and boiler Design parameters.																													
Outdoor Set Up	55	40 F to 100 F	The Outdoor Set Up temperature is the outdoor temperature at which the Boiler Set Up temperature is supplied. Only visible when Outdoor Sensor is set to Outdoor Reset .																													
Boiler Set Up	140	80F to 180 F	The Boiler Set Up Temperature is the starting boiler water temperature of the reset ratio. If the building feels cool during mild outdoor conditions, the Boiler Set Up setting should be increased. Only visible when Outdoor Sensor is set to Outdoor Reset.																													
Outdoor Design	30	-20 F to 50 F	The Outdoor Design Temperature is the outdoor temperature at which the Boiler Design temperature is supplied. Only visible when Outdoor Sensor is set to Outdoor Reset.																													
Boiler Design	180	80F to 220 F	The Boiler Design setting is the water temperature required to satisfy the building heat loss during the Outdoor Design temperature. If the building feels cool during cold outside conditions, the Boiler Design setting should be increased. Only visible when Outdoor Sensor is set to Outdoor Reset.																													
Blower SPD High	100	0 to 100 %	Percent of (0 - 10 vdc output (V+, V-) output that represents a 100% modulation rate. This scaling factor allows the controller to display 100% when the blower is at rated boiler output.																													
Blower SPD Low	0	0 to 100 %	Percent of (0 - 10 vdc output (V+, V-) output that represents a 0% modulation rate. This scaling factor allows the controller to display 0% when the blower is at minimum boiler output.																													
Low Fire Spd	50	0 to 100 %	Modulation % used for Low Fire Hold and Low Fire Start conditions.																													
Fan Purge Spd	See Description	0 to 100 %	Percent of blower operating range that the blower should be run during Fan Purge (at ignition). <table border="1" data-bbox="625 1417 1469 1575"> <thead> <tr> <th rowspan="2">Build</th> <th colspan="5">Boiler model</th> </tr> <tr> <th>750</th> <th>1000</th> <th>1500</th> <th>2000</th> <th>3000</th> </tr> </thead> <tbody> <tr> <td>Standard</td> <td>100</td> <td>100</td> <td>100</td> <td>100</td> <td>55</td> </tr> <tr> <td>Low fire proving</td> <td>25</td> <td>24</td> <td>23</td> <td>26</td> <td>55</td> </tr> <tr> <td>Venturi</td> <td>100</td> <td>100</td> <td>23</td> <td>26</td> <td>N/A</td> </tr> </tbody> </table>	Build	Boiler model					750	1000	1500	2000	3000	Standard	100	100	100	100	55	Low fire proving	25	24	23	26	55	Venturi	100	100	23	26	N/A
Build	Boiler model																															
	750	1000	1500	2000	3000																											
Standard	100	100	100	100	55																											
Low fire proving	25	24	23	26	55																											
Venturi	100	100	23	26	N/A																											

D. SETUP MENU (continued)

Display	Factory Settings	Range	Description
Low Fire Hold	20	10 to 1200 (s)	Time modulation rate is held at present value (Low Fire Spd or Fan Purge Spd depending on the state and configuration of spare input) after the Fuel Valve Energized Input (CS) is energized.
Post Purge Time	30	0 to 600 (s)	Time modulation rate is held at Fan Purge Spd after the Fuel Valve Energize Input (CS) is de-energized.
Local PID P	20	0 to 10000	Proportional Gain value for boiler outlet temperature sensor control Modes. A larger gain value results in tighter, more active, PID control. Gain is the primary PID modulation rate tuning adjustment and provides the immediate modulation rate response.
Local PID I	30	0 to 10000	Integral gain value for boiler outlet temperature sensor control Modes. A smaller value makes the Integral ramp in less time (i.e., faster). Integral is a secondary PID modulation rate tuning adjustment that ramps the output over time (typically minutes).
Local PID D	0	0 to 10000	The Derivative gain value for boiler outlet temperature sensor control Modes. A larger Derivative gain value produces a larger PID output contribution proportional to the rate of change of the error (Setpoint – Boiler Outlet Temperature). When set equal to zero it has no effect on the output.
Remote PID P	20	0 to 10000	Proportional Gain value for Remote System Temperature sensor control Modes. Refer to Local PID P for explanation.
Remote PID I	30	0 to 10000	Integral Gain Term for Remote System Temperature sensor control Modes. Refer to Local PID I for explanation.
Remote PID D	0	0 to 10000	Derivative Gain Term for Remote System Temperature sensor control Modes. Refer to Local PID D for explanation.
Mixing Valve P	10	0 to 10000	Proportional Gain value for boiler Inlet temperature sensor control mode. A larger gain value results in tighter, more active, PID control. Gain is the primary PID modulation rate tuning adjustment and provides the immediate mixing valve modulation response. Only visible when mixing valve = yes.
Mixing Valve I	60	0 to 10000	Integral gain value for boiler inlet temperature sensor control mode. A smaller value makes the Integral ramp in less time (i.e., faster). Integral is a secondary PID modulation rate tuning adjustment that ramps the output over time (typically minutes). Only visible when mixing valve = yes.
Mixing Valve D	0	0 to 10000	The Derivative gain value for boiler inlet temperature sensor control mode. A larger Derivative gain value produces a larger PID output contribution proportional to the rate of change of the error (Setpoint – Boiler Inlet Temperature). When set equal to zero it has no effect on the output. Only visible when mixing valve = yes.
Max Delta T P	10	0 to 10000	Proportional Gain value for boiler differential (boiler outlet minus inlet temperature sensor) temperature control mode. Refer to Local PID P for explanation. Only visible when mixing valve = yes.
Max Delta T I	60	0 to 10000	Integral Gain value for boiler differential (boiler outlet minus inlet temperature sensor) temperature control mode. Refer to Local PID I for explanation. Only visible when mixing valve = yes.
Max Delta T D	0	0 to 10000	Derivative Gain Term for boiler differential (boiler outlet minus inlet temperature sensor) temperature control mode. Refer to Local PID D for explanation. Only visible when mixing valve = yes.

E. BOILER CONFIGURATION MENU

Display	Factory Setting	Range/ Choices	Description
Display Units	Deg F	Deg F Deg C	Selects how temperature parameter values are displayed.
Boiler Pump	Purge	None Always On Purge Lead On	None: No Boiler Pump. Always On: Pump Runs Continuously. Purge: Pump Runs during pump pre/post purge operations and during call for heat and then turns off. Lead On: Lead boiler's pump runs continuously when the boiler is the lead boiler and reverts to "Purge" operation when it is a lag boiler.
Pump Prepurge	15	0 to 600 (s)	Sets length of time the boiler pump will be run prior to closing the "Call for Heat" relay (CH). Only visible when <i>Boiler Pump</i> does not equal None .
Postpurge Delta	5	0 to 20 (C or F)	Defines the temperature above BIT that BOT must be at or below before turning off the boiler pump during pump post purge (Pump Cooldown State). Only visible when <i>Boiler Pump</i> does not equal None .
Inlet Sensor	Yes	No Yes	Enables the inlet temperature display and control logic.
Mixing Valve	Yes	No Yes	Enables the mixing valve control output and user display.
Set Time/Date	-	hour : minute Month / day / year	Sets the time and date of the boiler's real time clock. This item also displays the time and date.
Spare Input	Off	Off Sys Pump FB Low Fire	Sets the function of the Spare Input Terminal (SI). Off: Ignore. Sys Pump Feedback: Input (SI) should be wired to a flow switch inserted in the flow path of the primary system pump. Input (SI) indicates the primary system pump is operating. If output (SP) is set to System Backup Pump, system pump output (SP) is energized and System pump Feedback is de-energized the System Backup Pump output (SP) is energized. Low Fire: When the Fuel Valve Energized input (CS) is not energized and Input (SI) is energized the modulation rate is set to the "Low Fire Spd" setpoint. When input (SI) is not energized the modulation rate is set to "Fan Purge Spd" setpoint. When the fuel valve energized input (CS) is energized input (SI) is ignored.
Fuel limit	Yes	No Yes	Specifies whether high and low gas pressure switches are connected to input (GP). Enables Fuel Limit Hold and alarm messages.
Spare output	Off	Off CAD System Pump BU Soft Alarm	Sets the function of the Spare Output Terminal (SO). Off: Never close output (SO). CAD: Closes SO relay with a call for heat, Opens SO relay 2 minutes after call for heat has been de-activated. System Pump BU: Closes when System Pump output is activated but the System Pump Feedback indicates the Primary System Pump is not operating. Soft Alarm: Closes when a any alarm is active.

F. SYSTEM CONFIGURATION MENU

Display	Factory Settings	Range	Description
DHWP	Off	Off Isolated Demand Shared Demand	Enables Domestic Hot Water Priority (DHWP) control feature. When input (DP) is energized DHWP becomes active as selected. Off: No DHWP. Isolated Demand: Boiler that receives the input (DP) drops off the Peer-To-Peer network and it's temperature setpoint is adjusted above the DHWP Setpoint. The PID output is based on boiler outlet temperature and setpoint. If Remote SP or Remote System temperature sensors were selected, control is switched to the Boiler Outlet Sensor. Shared Demand: If the lead boiler receives the input (DP) the temperature setpoint for all boilers on the peer-to-peer network is adjusted above the DHWP Setpoint.
Remote Control	No	No Remote SP Modbus SP Remote Mod Modbus Mod	Sets the remote (Energy Management System) control mode as follows. No: Local setpoint and modulation rate is used. Modbus and remote input (C+,C-) are ignored. Remote SP: Remote Input (C+, C-) is used as the temperature setpoint. Parameter 22 & 23 may be used to adjust the signal range. Modbus SP: RS485 Modbus (40006) is used as the temperature setpoint. Remote Mod: Remote Input (C+, C-) is used as the modulation rate. Modbus Mod: RS485 Modbus (40006) is used as the modulation rate.
Remote 1.0 volt =	140	60 F to 170 F	Sets the temperature corresponding to input (C+,C-) 1V. Voltage below 1V is considered invalid, (failed or miss wired sensor). Only visible when <i>Remote Control</i> equals Remote SP .
Remote 9.0 volt =	220	150 F to 220 F	Sets the temperature corresponding to input (C+,C-) 9 Volts. Voltage above 9V is considered invalid, (failed or miss wired sensor). Only visible when <i>Remote Control</i> equals Remote SP .
Remote Sensor	Control	No Display Only Control	Enables the Remote System Temperature sensor display and control logic. No: Remote Sensor Input (R+,R-) is ignored. Display Only: Remote Sensor Input (R+,R-) is used for display only. Control: Remote Sensor Input (R+,R-) is compared with the temperature setpoint to establish a modulation rate.
System Pump	No	No Yes	Enables the System Pump output (SP).
LWC or CAD	Yes (If applicable)	No Yes	Specifies a Low Water Cut-off Switch or Combustion Air Damper (Fresh Air Damper). Open switch is connected to input (LC). Enables Limit Hold and Alarm Messages.
"Low Water Level"	"Low Water Level"	16 Text Characters	Only visible if LWC or CAD is selected. The Limit hold and Alarm message displayed corresponding to the sensor connected to input (LC). The "Enter" key and "Up" and "Down" arrow keys are used to change the text message.

G. SETPOINTS MENU

Display	Factory Settings	Range/Choices	Description
Operational SP	180	60 to 230 F	Setpoint used in Local Setpoint Mode when not servicing a Domestic Hot Water Priority (DHWP) request
On Point	-5	0 to 99 F	The boiler starts when the water temperature drops 'On Point' degrees below the setpoint.
Off Point	15	0 to 99 F	The boiler stops when the water temperature rises 'Off Point' degrees above the setpoint.
High Temp Stop	Boilers 230	60 to 230 F	The boiler stops when water temperature is above the High Temperature Stop setpoint. This setpoint is active in every control mode.
DHWP Setpoint	180	140 to 230 F	The Domestic Hot Water Priority (DHWP) Setpoint is active when DHW Input (DP) closes and "DHWP" parameter is set to "yes" and Local SP Mode is selected. When the contact is closed, the boiler outlet is maintained at, or above, the DHW Setpoint. Only visible when <i>DHWP</i> equals Yes .
WWSD Setpoint	70	40 to 90 F	The Warm Weather Shutdown (WWSD) Setpoint used to disable boiler and or system pump operation when enabled by setting the "WWSD" parameter to "WWSD of Boiler", "WWSD of Sys Pump" or "Both" Only visible when <i>WWSD</i> does not equal Off .
Max SP	Boilers 230	140 to 230 F	The Maximum Operational Setpoint for all possible Local and Remote modes
Min SP	70	60 to 230 F	The Minimum Operational Setpoint is the lower limit for all Local and Remote modes
Min BIT	120	110 to 235 F	Low Boiler Inlet Temperature alarm and event setpoint.
Min In H2O Temp	130	110 to 180 F	Minimum Inlet Water Temperature setpoint used as the Mixing Valve inlet temperature setpoint. Only visible when <i>Mixing Valve</i> equals Yes .
Max H2O Delta T	50	20 to 50 F	Maximum Water Differential (Boiler Outlet minus Boiler Inlet) Temperature setpoint used as the Mixing Valve differential temperature setpoint. Only visible when <i>Mixing Valve</i> equals Yes .
Max Delta T Hold	50	20 to 50 F	Maximum Water Differential (Boiler Outlet minus Boiler Inlet) Temperature used to hold modulation rate at low fire.

H. COMMUNICATION MENU

Display	Factory Settings	Range/Choices	Description
Protocol	Peer to Peer	Peer to Peer Modbus	Selects between Peer-To-Peer (multiple boiler Lead/Lag control network) and a Modbus slave communication.
Modbus Address	1	1 to 247	Each boiler must be given a unique address. Only visible when <i>Protocol</i> equals Modbus.
Baud Rate	19.2	9.6 19.2 38.4	Units are 1000 Bits Per Second (KBPS). Only visible when <i>Protocol</i> equals Modbus.
Parity	Odd	Odd Even None	Only visible when <i>Protocol</i> equals Modbus.
Timeout	30	1 to 120	Only visible when <i>Protocol</i> equals Modbus.
Messages Rcvd			Diagnostic tool used to confirm wiring and Modbus master configuration. Only visible when <i>Protocol</i> equals Modbus.
Messages Sent			Diagnostic tool used to confirm wiring and Modbus master configuration. Only visible when <i>Protocol</i> equals Modbus.
Boiler Address	1	1 to 8	Each boiler must be given a unique address. The boiler address assignment determines the boiler sequencing order. A value of 0 disables the network communications. Only visible when <i>Protocol</i> equals Peer to Peer.
Online Status		XXXXXXXX	Each space can be either the boiler address or a ' - ' depending on whether there is a boiler of that address on-line. Example: - - 6 - - - 321 indicates that boilers 6,3,2 and 1 are online. Only visible when <i>Protocol</i> equals Peer to Peer.

I. MANUAL MODE MENU

Display	Factory Settings	Range/Choices	Description
Boiler Man/Auto	Auto	Man Auto	Man: Remain in Manual Mode. Auto: Return to Boiler Mode specified by parameter/boiler conditions. Activated only when in Supervisor Mode.
Modulation Rate	Varies	0 to 100	Sets the modulation rate to be used for boiler when in Manual Mode. Activated only when in Supervisor Mode and Boiler Man/Auto = Man.
Boiler On/Off	Varies	On, Off	Sets the boiler start/stop status when in Manual Mode. No: Turn off boiler if running, otherwise remain off. Yes: Turn on boiler if off, otherwise remain on. Activated only when in Supervisor Mode and Boiler Man/Auto = Man.
Mixing Valve M/A	Auto	Man Auto	Man: Remain in Manual Mode. Auto: Return to Control Mode specified by parameter/boiler conditions. Activated only when in Supervisor Mode.
Mixing Valve	Varies	0 to 100	Sets the Mixing Valve % Open to be used for valve when in Manual Mode. Activated only when in Supervisor Mode and Mixing Valve M/A equals Man.

NOTES

NOTES

NOTES

X. Warranty

Thermal Solutions

("seller")

LIMITED WARRANTY

LIMITED WARRANTY

Subject to the terms and conditions herein and except as provided below with respect to products or parts not manufactured by Thermal Solutions, Seller warrants to the original owner at the original installation site that products manufactured by Seller ("Products") comply, at the time of manufacture, the primary heat exchanger with recognized hydronics industry regulatory agency standards and requirements then in effect and will be free from defects in materials and workmanship for a period of 5 years from date of shipment (the "Warranty Period"). The secondary heat exchanger is also covered under the limited warranty for 3 years and the burner for 10 years from the date of shipment (the "Warranty" Period). For products or parts not manufactured by Thermal Solutions, the warranty obligations of Thermal Solutions shall, in all respects, be limited to one year.

REMEDY

- A. The sole remedy for breach of this warranty is expressly limited to the repair or replacement of any part found to be defective under conditions of normal use within the Warranty Period. Labor for removal and/or installation is not included.
- B. Warranty - The owner must notify the original installer of the Product and Seller (Attention: Thermal Solutions, P.O. Box 3244, Lancaster, PA 17604-3244), in writing, within the Warranty Period, providing a detailed description of all claimed defects. Transportation to a factory or other designated facility for repairs of any products or items alleged defective shall, in all events, be the responsibility and at the cost of the owner.

EXCLUSIONS

Seller shall have no liability for and this warranty does not cover:

- A. Incidental, special or consequential damages, such as loss of the use of products, facilities or production, inconvenience, loss of time or labor expense involved in repairing or replacing the alleged defective Product.
- B. The performance of any Product under conditions varying materially from those under which such Product is usually tested under industry standards as of the time of shipment.
- C. Any damage to the Product due to abrasion, erosion, corrosion, deterioration, abnormal temperatures or the influence of foreign matter or energy.
- D. The design or operation of owner's plant or equipment or of any facility or system of which any Product may be made a part.
- E. The suitability of any Product for any particular application.
- F. Any failure resulting from misuse, modification not authorized by Seller in writing, improper installation or lack of or improper maintenance.

- G. Equipment furnished by the owner, either mounted or unmounted, or when contracted for by the owner to be installed or handled.
- H. Leakage or other malfunction caused by:
 - 1. Defective installations in general and specifically, any installation which is made:
 - a. in violation of applicable state or local plumbing housing or building codes,
 - b. without a certified ASME, pressure relief valve, or
 - c. contrary to the written instructions furnished with the unit.
 - 2. Adverse local conditions in general and, specifically, sediment or lime precipitation in the tubes and/or headers or corrosive elements in the atmosphere.
 - 3. Misuse in general and, specifically, operation and maintenance contrary to the written instructions furnished with the unit, disconnection, alteration or addition of components or apparatus, not approved by seller, operation with fuels or settings other than those set forth on the rating plate or accidental or exterior damage.
- I. Production of noise, odors, discoloration or rusty water.
- J. Damage to surrounding area or property caused by leakage or malfunction.
- K. Costs associated with the replacement and/or repair of the unit including: any freight, shipping or delivery charges, any removal, installation or reinstallation charges, any material and/or permits required for installation reinstallation or repair, charges to return the boiler and or components.

Seller's liability under this warranty shall not in any case exceed the amount paid for the Product found to be defective.

THIRD-PARTY WARRANTIES

For goods or components not manufactured by Seller, the warranty obligations of Seller shall, in all respects, conform and be limited to one year from the date of shipment

SEVERABILITY

To the extent that any provision of this warranty would be void or prohibited under applicable law, such provisions shall be limited in effect to the minimum extent necessary to render the remaining provisions hereof enforceable.

